

# SECTIONAL VALVE

## VD8A

Technical catalogue

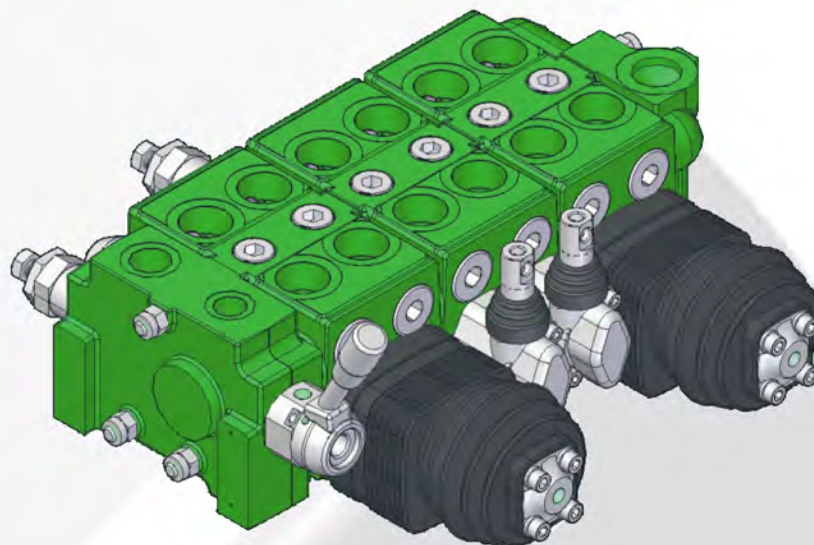

E0.06.0911.02.02

COMPANY  
WITH QUALITY SYSTEM  
CERTIFIED BY DNV  
=ISO 9001/2000=

**salamj** ™



## Page 1 - GENERAL INDEX

Page 2 - General features

Page 3 - Technical data - Working conditions

Page 4 - Operating principle

Page 5 - Hydraulic fluids - Installation - Filtration - Pipes

Page 6 - Performance data - Metering curves - Valve working limit

Page 7 - Performance data - Pressure drop "P" to "T" - Pressure drop "P" to "A/B" and "A/B" to "T"

Page 8 - Dimensions from 1 to 8 working modules

Page 9 - Ports

Page 10 - Inlet module (hydraulic circuits)

Page 11 - Inlet module (dimensions)

Page 12 - Inlet module with priority flow valve adjustable by power steering load

Page 13 - Inlet module with priority flow valve (fixed priority flow)

Page 15 - Single and double working module (parallel circuit)

Page 16 - Working module with adjustable or fixed priority flow valve pressure compensated

Page 17 - Single and double working module (series circuit)

Page 18 - Working module (tandem circuit)

Page 19 - Mid inlet module (hydraulic circuits)

Page 20 - Outlet module (hydraulic circuits)

Page 21 - Assembling tie-rods

Page 22 - 23 - Circuit and spool types

Page 24 - Main relief valves

Page 25 - Venting valves (available as auxiliary valve too)

Pages 26 - 27 - 28 - Auxiliary valves

Page 29 - Spool controls and spool positionings

Page 30 - Spool controls - SL - NL - NP - MP

Page 31 - Spool controls - SS - FL

Page 32 - Spool controls - L1/L2 - Standard shafts

Page 33 - Cable remote controls - D1 - TC

Page 33 - Direct electric push-pull control and emergency devices - E1/E2 - SL - ES

Page 34 - Hydraulic controls - IP - IF

Page 35 - Pneumatic and electro-pneumatic controls - PP/P0 - P1/P2 - PQ

Page 36 - 37 - Electro-hydraulic controls - H1/H2

Page 38 - Spool positionings - C2 - C3 - C4 - C5 - C6 - C7 - C8

Page 39 - Spool positionings - R2 - R4 - R5 - R6 - R7 - R9 - C0

Page 40 - Spool positionings - F1 - F2 - F3 - F4 - F5 - F6 - F7 - F8

Page 41 - Spool positionings - D7 - D8 - D9 - M1 - M2 - M3

Page 42 - Spool positionings - CE - CM - CW - CD

Page 43 - Spool positionings - PM - G2 - G4 - G5

Page 44 - 45 - How to order - VD8A

Page 46 - Identification label

## Page 47 - WARRANTY

## E0.06.0911.02.02

The data in this catalogue refers to the standard product.

The policy of Salami S.p.A. consists of a continuous improvement of its products. It reserves the right to change the specifications of the different products whenever necessary and without giving prior information.

If any doubts, please get in touch with our sales department.

## GENERAL FEATURES

Among all hydraulic directional control valves used in the field of mobile equipment applications, the spool valve is the most popular.

The sectional valve type allows construction flexibility. Salami VD8A directional control valve is modular construction and consist of an inlet section, up to 8 working modules and an outlet section. All these elements are secured in one block by means of tie-rods. (For more than 8 working modules please contact our sales dept.)

### FEATURES

VD8A directional control valve has the following:

- cast-iron body (inlet section, working section, outlet section)
- parallel circuit, load check valve protection on each section
- series circuit, load check valve protection on each section (possibility of 2<sup>nd</sup> load check valve on series line)
- tandem circuit, load check valve protection on each section
- several types of mid modules
- possibility of venting valve
- possibility of power beyond configuration
- spool construction in steel, hardened and chromium-plated to obtain a higher surface hardness and a better corrosion resistance
- several types of spool: double, single acting, spool motor, float position etc.
- minimum tolerance between the spools and the body to obtain a minimum internal leakage
- interchangeability of all the spools
- possibility of auxiliary valve either on port A or B or on both
- several spool control devices and spool positioning devices

### VALVE AND DEVICE TYPES

In order to meet the most stringent demands and to offer a wider range of applications, the following types of valves and devices are available:

#### Valves

- direct main relief valve: controls the maximum pressure in the circuit when one or more spools are on end stroke located on "A" or "B" port side, can be:  
direct type version up to 260 bar - 3700 psi  
pilot operated with anticavitation version up to 350 bar - 5000 psi
- electric and external piloted venting valve: located in the opposite cavity of the main relief valve and is available as 12 or 24 Vdc and normally open or normally closed versions (available also as venting valve for the ports A and B)
- overload and anticavitation valve on port A or/and B: set at a higher value (in comparison with the main relief valve), it protects the working ports from load induced pressures, avoids cavitation in the system created by the inertia.
- anti-cavitation check valve on port A or/and B: avoids cavitation in the system created by the inertia.
- flow restrictor: directly fitted on the "A/B" ports orifice

#### Devices

- handle controls
- handle safety devices: avoids accidental operation of the spool
- cross lever: allows to acting two spools with one manual joystick
- cable remote control
- control device for microswitches: for the operation with electric d.c. motor driven pumps at one or more rotation speeds
- hydraulic kick-out: returns the spool automatically to the neutral position when the preset pressure of port "A" or "B" is exceeded
- anti-tilt device: the spool returns automatically in neutral position when the pressure reaches a pre-set value to avoid cranes from becoming unstable
- pneumatic proportional control
- electropneumatic control
- hydraulic proportional control
- direct electric on-off control with emergency manual device
- electrohydraulic on-off and proportional control
- several spool positionings device to return the spool to neutral position or to lock the spool on working position

**TECHNICAL DATA**

Spools	from 1 to 8 (for more working modules pls. contact our sales department)		
Nominal flow	Q	75 l/min	( 20 gpm US )
Max flow*		90 l/min	( 24 gpm US )
Max pressure	port P	350 bar	( 5100 psi )
	ports A/B	350 bar	( 5100 psi )
	port T*	25 bar	( 363 psi )
Internal leakage at 160 bar ( 2285 psi )	ports A/B → T	25 ÷ 35 cm <sup>3</sup> /min ( 1.52 ÷ 2.13 cu.in./min )	
For lower leakage please contact our sales dept.			
In case of solenoid control the leakage is		120 ÷ 160 cm <sup>3</sup> /min ( 7.32 ÷ 9.76 cu.in./min )	
Spool stroke (positions 1 and 2)		± 7 mm	( 0,28 in. )
Spool stroke (position 4, float or regenerative)		± 7 + 5 mm	( 0.28 + 0.19 in. )
For solenoid control - spool stroke		± 5 mm	( 0,19 in. )
*In case you need the max flow please contact our sales dept.			
*For higher back pressure please contact our sales dept.			
All technical data carried out using mineral oil with viscosity of 16 cSt and contamination level 19/16 as ISO 4406.			

Nominal flow meaning: flow causing 1 bar (14.5 psi) pressure drop each section, with spools in neutral position

**WORKING CONDITIONS**

Hydraulic fluid	mineral oil according to DIN 51524		
Viscosity	viscosity range	10...400 mm <sup>2</sup> /sec	( 0.15...7.13 sq.in./sec )
	optimal viscosity	12...75 mm <sup>2</sup> /sec	( 0.19...1.16 sq.in./sec )
Temperature	fluid range temperature	-20...85 °C	( -4...185 °F ) NBR seals
	suggested range	30...60 °C	( 86...140 °F ) NBR seals
Maximum contamination level	NAS 1683: class 9 ISO 4406: 19/16		
Room temperature	-30...60 °C ( -22...140 °F )		
Working limits	see diagrams at page 6		
Pressure drop	see diagrams at page 7		
For operation with fire resistant fluid, please contact our sales department			

## OPERATING PRINCIPLE

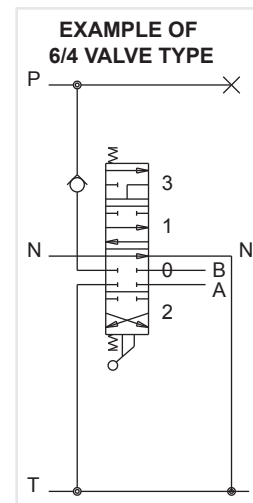
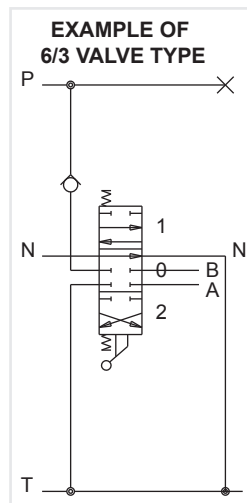
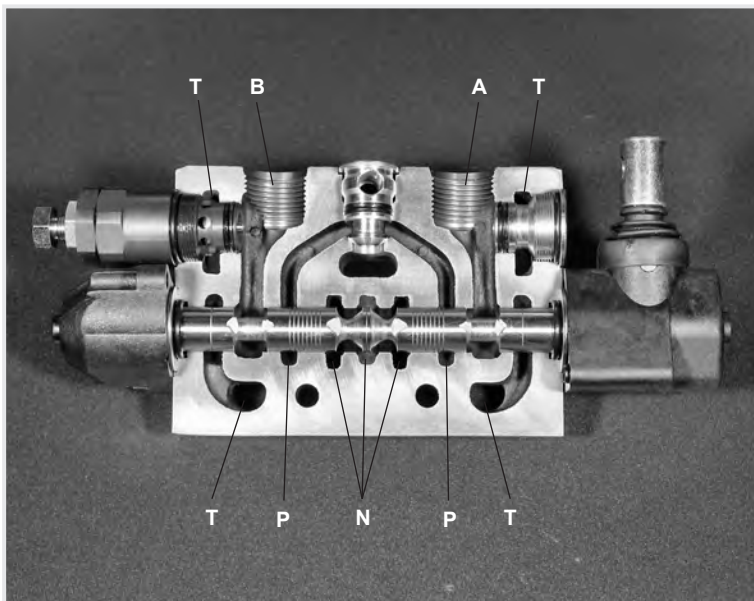

The picture show the P working module with the paths N - P - A - B - T.

Salami directional control valves belong to the 6/3 (or 6/4) type; they can control 6 gallery in 3 (or 4) spool positions simultaneously.

They are open circuit types: when the spool is in neutral position, the fluid flows directly to the tank with minimum internal pressure drops (approximately 1 bar / 14.5 psi for each spool at nominal flow).

When the spool is moved from this position, the neutral gallery is gradually throttled and the connection between pump and actuator, through the corresponding port, is made.

When a pressure exceeds the value of the pressure existing in port A or B, the fluid flows through the load check valve to the actuator.

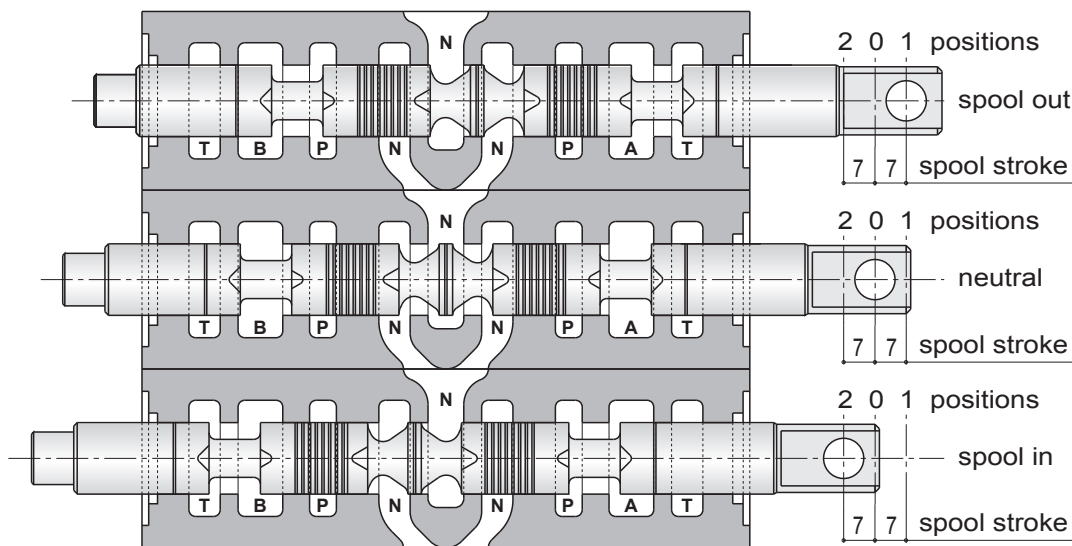

**IMPORTANT**  
Looking at this side of the spool, we usually say: spool in when the spool is pushed into the valve and spool out when it is pulled out of the valve. Depending on assembling of the spool on "A" or "B" side

There are two characteristic phases in the spool stroke (7 mm - 0,275 in.):

- a) the overlap phase (about 18% of the stroke) guarantees minimum internal leakages in neutral position;
- b) the progressive flow regulation phase (82% of the stroke).

Both pictures show a 6/3 valve type with double acting spool only as principle of functioning.

Salami VD8A is available in different solutions.

**HYDRAULIC FLUIDS**

Usually a mineral-base oil with a good viscosity index should be used, preferably with good lubricating properties and corrosion, oxidation and foaming resistant.

Sometimes the fluids supplied by the manufacturers do not satisfy purity requirements (see page 3 WORKING CONDITIONS). It is therefore necessary to filter the fluid carefully before filling. Your supplier can give you the information about NAS class of its fluids. To maintain the proper purity class, the use of filters of high dirt capacity with clogging indicator is recommended.

Under humidity conditions it is necessary to use hygroscopic salts.

For operation with fire resistant and ecological fluids, please contact our technical department.

**INSTALLATION**

When proceeding to mount the unit on the structure and to connect fittings to work ports, it is necessary to comply with the values of tightening torques.

The attachment of linkages to spools should not affect their operation. The mounting position can be vertical with inlet module on the top or horizontal.

**Standard tightening torques - Nm / lbft**

FITTING TYPE	P and PL ports	A and B ports	T and TL ports
BSP (ISO 228/1)	G 3/4	G 1/2	G 3/4
with o-ring seal	<b>60 / 44.2</b>	50 / 36.9	<b>60 / 44.2</b>
with copper washer	70 / 51.6	60 / 44.3	70 / 51.6
with steel washer	70 / 51.6	60 / 44.3	70 / 51.6
SAE	<b>SAE 10 (7/8-14 UNF)</b>	SAE 10 (7/8-14 UNF)	SAE 12 (1 1/16-12 UN)
with o-ring seal	<b>60 / 44.2</b>	60 / 44.2	95 / 70.1

**FILTRATION**

The contamination of the fluid in the system greatly affects the life of the unit. Above all, contamination may result in irregular operation, wear of seals in valve housings and failures. Once the initial contamination level of the system has been reached, it is necessary to limit any increase of contamination installing an efficient filtration system (see working conditions page 3).

**PIPES**

Pipes should be as short as possible, without restrictions or sharp bends (especially the return lines). Before connecting pipes to the fittings of the corresponding components, make sure that they are free from burrs and other contamination.

As a first approximation, for a mobile machine with standard length pipes, their width should guarantee the following values of fluid speed\*:

6 ÷ 10 m/sec	inlet pipe	19,7 ÷ 32,8 ft/sec	inlet pipe
3 ÷ 5 m/sec	outlet pipe	9,9 ÷ 16,4 ft/sec	outlet pipe

the lowest values of fluid speed are required in case of wide temperature range and/or for continuous duty.

$$* [v = \frac{21,2 \times Q}{d^2}] \quad v = \text{fluid speed [m/sec]}, Q = \text{flow [l/min]}, d = \text{pipe internal diameter [mm]}$$

## PERFORMANCE DATA

The characteristics in this catalogue are typical measured results.  
During measuring a mineral based hydraulic oil with a viscosity of 16 cSt at a temperature of 50°C was used.

**FOR FURTHER DETAILS PLEASE CONTACT OUR SALES DEPARTEMENT**

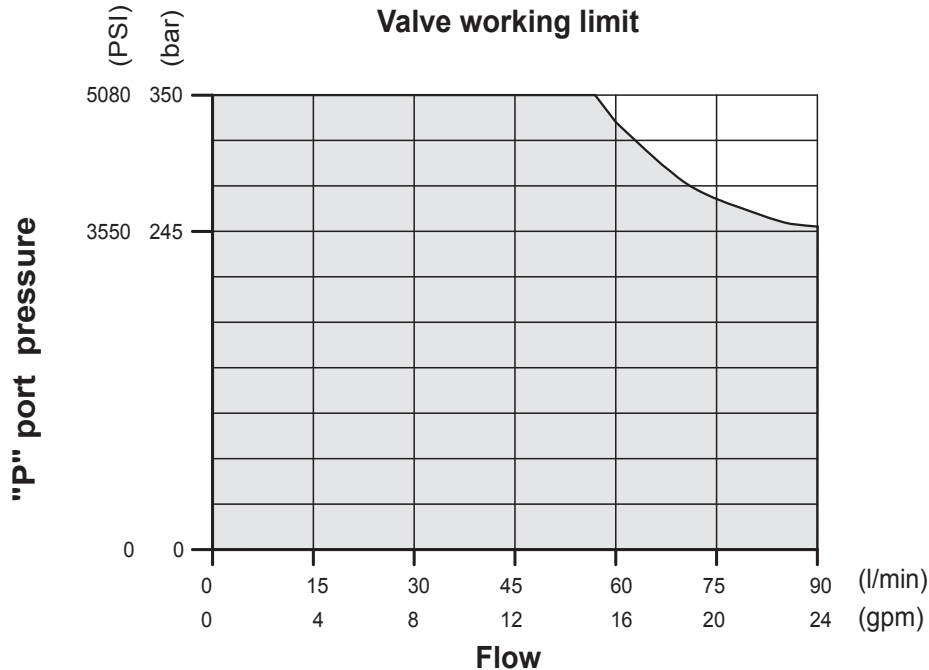
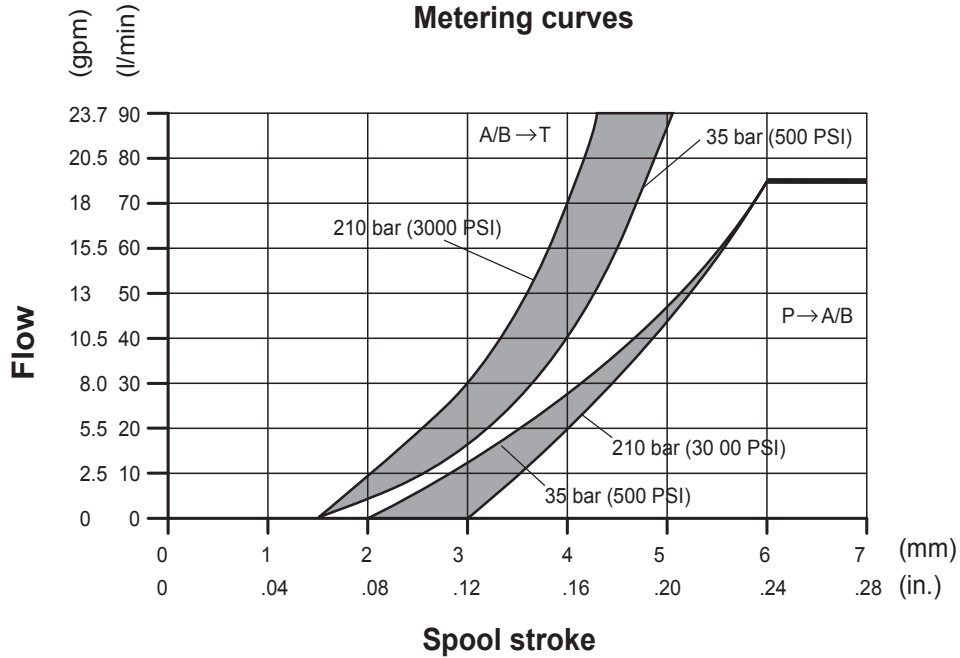

The data of this diagram have been obtained with a force of:  
stroke beginning 120 N - stroke end 180 N and standard leakage data.





**PERFORMANCE DATA**

The characteristics in this catalogue are typical measured results.  
During measuring a mineral based hydraulic oil with a viscosity of 16 cSt at a temperature of 50°C was used.

**FOR FURTHER DETAILS PLEASE CONTACT OUR SALES DEPARTEMENT**

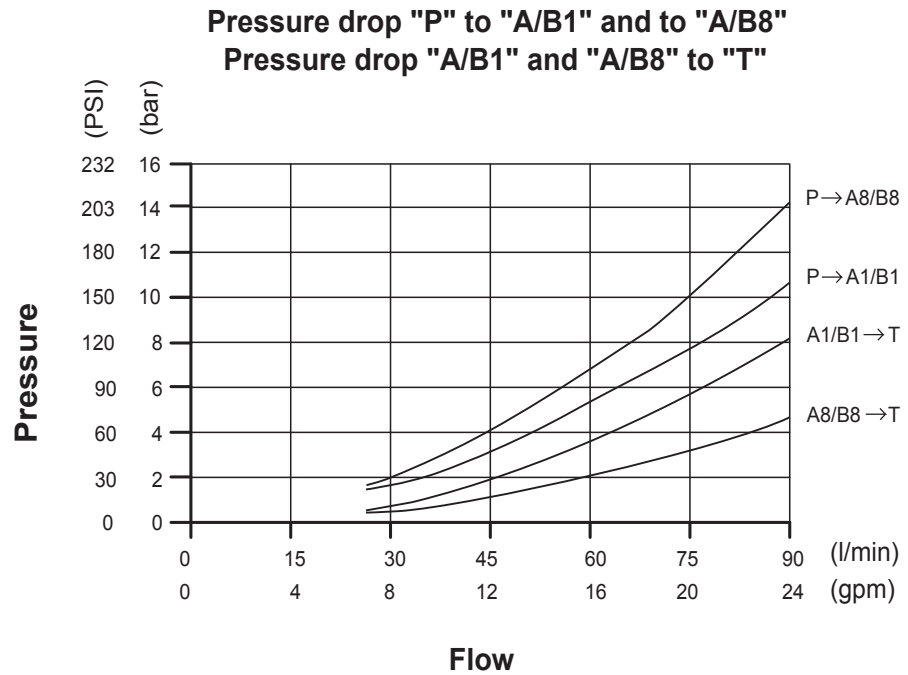
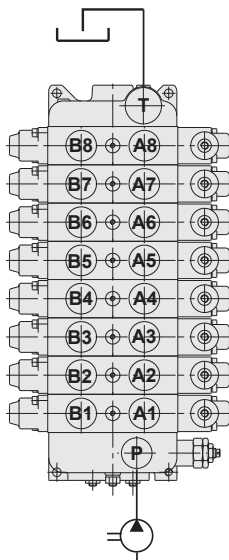
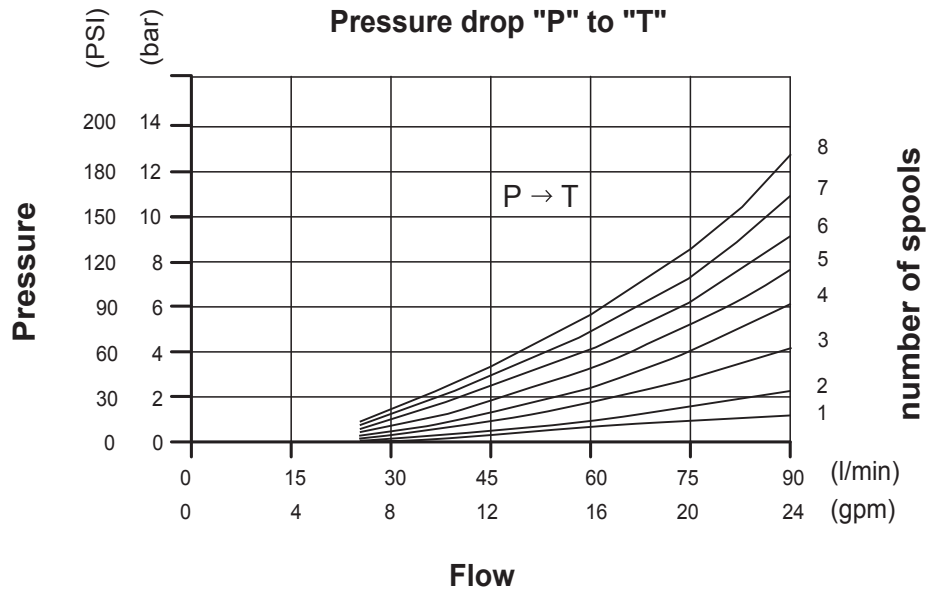
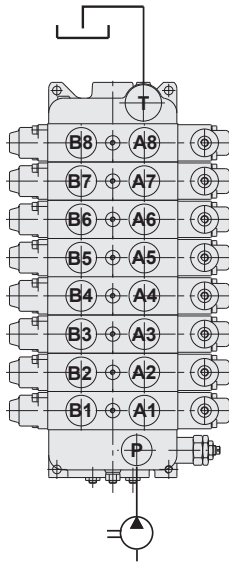

## DIMENSIONS FROM 1 TO 8 WORKING MODULES

FIXING HOLES THREADS:

PORTS THREADED BSP (ISO 228) - M8x1.25 ISO 262

PORTS THREADED METRIC (ISO 262) - M8x1.25 ISO 262

PORTS THREADED SAE UN-UNF (ISO 725) - 5/16 18 UNC

PORTS THREADED BSPF O-RING BOSS (JIS B 2351) - M8x1.25 ISO 262

On request are available working modules with  
distance between axis of 38 mm - 1.49 inch.

Please get in touch with our sales dept.

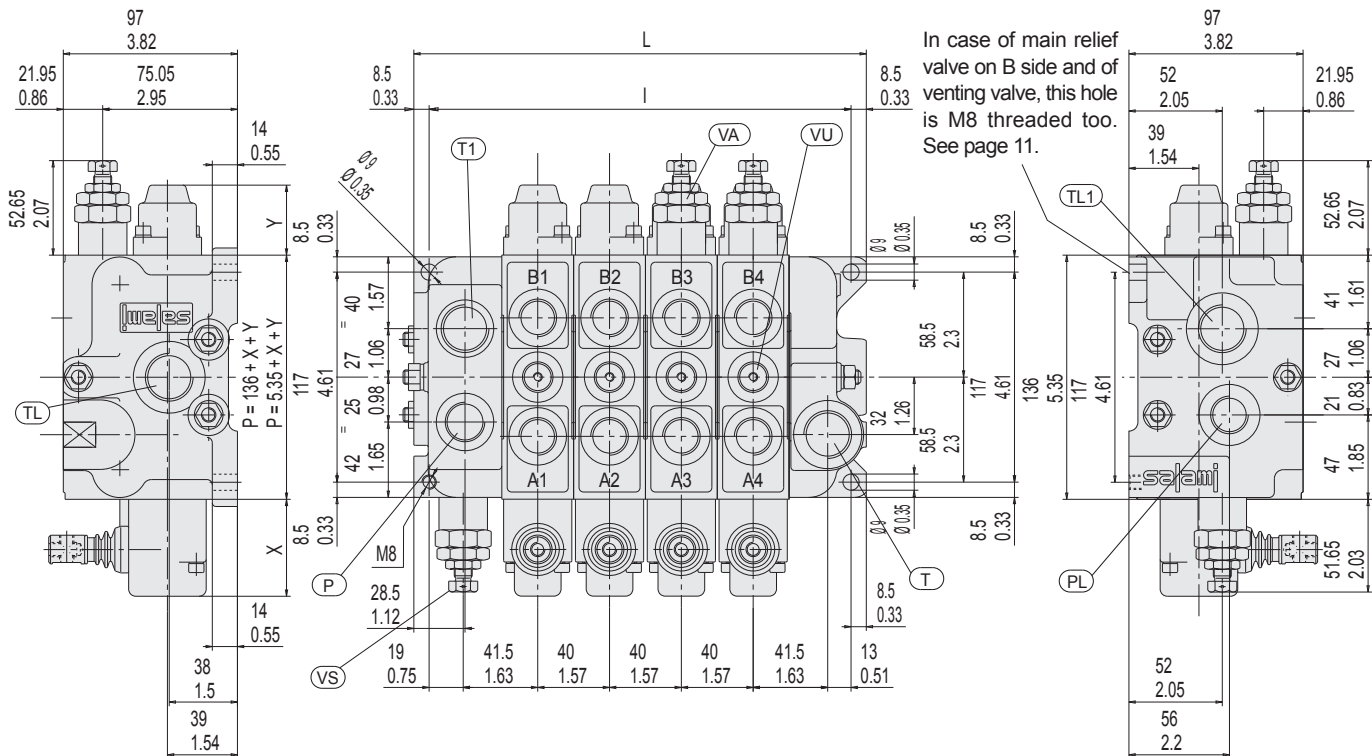

The drawing shown is just an example. The overall dimensions you read are valid for all the VD8A except the parametric dimensions "L" and "I" depending of the number of working sections. The parametric dimension "P" depends on a fixed dimension of 136 mm (11 in.) to which you have to add the "X" and "Y" dimensions that you can find in the spool controls and spool positionings pages.

### INDEX:

**P** = top inlet port

**PL** = side inlet port

**T** = top outlet port

**TL** = side outlet port

**T1** = top outlet port\*

**TL1** = side outlet port\*

**A/B** = work ports

**VS** = main relief valve (adjustable)

**VA** = overload valve

**VU** = load check valve

\*Only in case of inlet and outlet first module  
the end module is closed

Spools		1	2	3	4	5	6	7	8
<b>I</b>	mm	115	155	195	235	275	315	355	395
	in	4.53	6.10	7.68	9.25	10.83	12.40	13.97	15.55
<b>L</b>	mm	143.5	183.5	223.5	263.5	303.5	343.5	383.5	423.5
	in	5.65	7.22	8.80	10.37	11.95	13.52	15.10	16.67
<b>Mass</b>	kg	11	14.5	18	21.5	25	28.5	32	35.5
	lb	24.2	31.9	39.6	47.3	55	62.7	70.4	78.1

For different size and thread ports, please contact our sales department

PORT SIZES	P - PL - P3	T - TL	A - B
<b>BSP ISO 228</b>	<b>G 1/2</b>	<b>G 3/4</b>	<b>G 1/2</b>
<b>SAE ISO 176</b>	<b>SAE#10 7/8 - 14 UNF</b>	<b>SAE#12 1-1/16 - 12 UNF</b>	<b>SAE#10 7/8 - 14 UNF</b>
<b>ISO 262 - ISO 6149</b>	<b>M 22 x 1.5</b>	<b>M 27 x 2</b>	<b>M 22 x 1.5</b>
<b>BSPF JIS B 2351</b>	<b>G 1/2</b>	<b>G 3/4</b>	<b>G 1/2</b>

On request you can have all the ports **BSP ISO 228 - G 3/4**  
in this case auxiliary valves are not available.

## PORTS

Following are standard ports. For different port types, please contact our sales department.

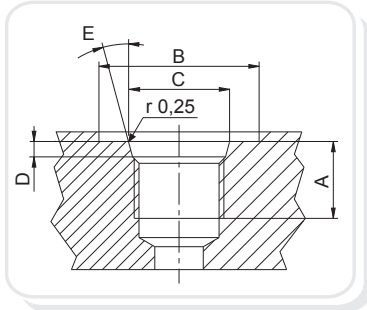

SAE UN-UNF (ISO 725)							
Dimensions		7/8 -14 UNF SAE10		1"1/16 -12 UN SAE12		1"5/16 -12 UN SAE16	
mm	In.						
A		17	0,67	20	0,79	20	0,79
B		34	1,34	41	1,61	49	1,92
C		23,9	0,94	29,2	1,15	35,5	1,40
D		2,5	0,10	3,3	0,13	3,3	0,13
E		15°		15°		15°	

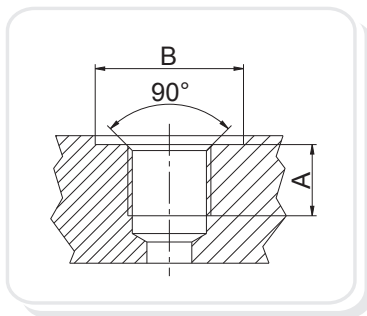

BSP (ISO 228)							
Dimensions		G1/2		G3/4		G1	
mm	In.						
A		16	0,63	18	0,71	20	0,79
B		27	1,06	33	1,30	40	1,57

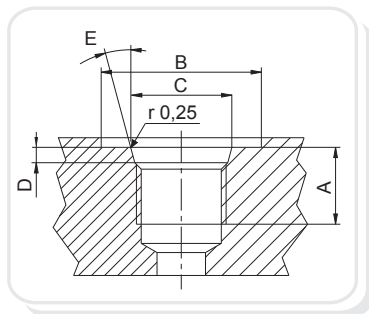

METRIC (ISO 262 - ISO 6149)*									
Dimensions		M22 x 1.5				M27 x 2			
mm	In.	ISO 262		ISO 6149		ISO 262		ISO 6149	
A		16	0,63	16	0,63	18	0,71	19	1,75
B		31,5	1,24	34	1,34	37,7	1,48	40	1,57
C				23,8	0,94			29,4	1,16
D				2,4	0,09			3,1	0,12

\*Available for quantity, please contact our sales dept.

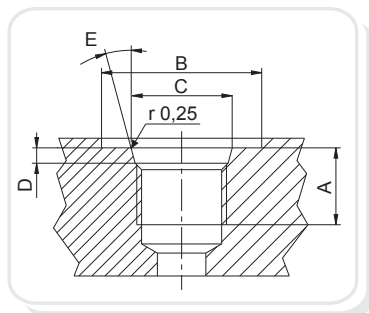

BSPF O-RING BOSS (JIS B 2351)							
Dimensions		G 1/2		G 3/4		G 1	
mm	In.						
A		16	0,63	17	0,67	21	0,83
B		34	1,34	45	1,77	51	2,01
C		22,6	0,89	29,8	1,17	35,8	1,41
D		2,5	0,10	3,5	0,14	3,5	0,14
E		15°		15°		15°	

## INLET MODULE (HYDRAULIC CIRCUITS)

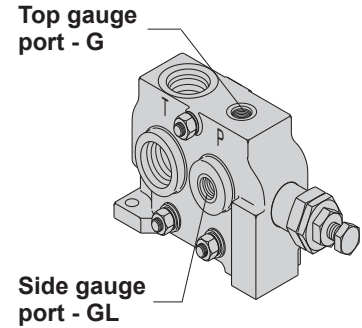
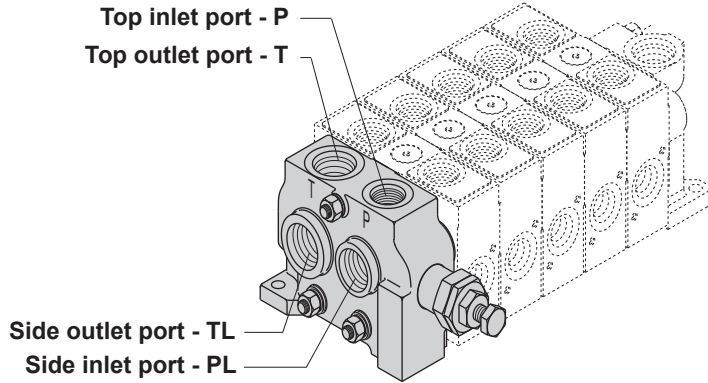

Gauge ports are available with the following threads:  
**BSP (ISO 228) - G 1/4**  
**SAE UN-UNF (ISO725) - SAE 4**

## COMMERCIAL CODES

<p><b>01</b> Top inlet port</p>	<p><b>02</b> Side inlet port top inlet port plugged</p>	<p><b>03</b> Top and side inlet ports</p>	<p><b>07</b> Top inlet and outlet ports</p>	<p><b>08</b> Side inlet and outlet ports top ports plugged</p>
<p><b>21</b> Top inlet port with side gauge port</p>	<p><b>22</b> Side inlet port with top gauge port</p>	<p><b>23</b> Top inlet port with top gauge port</p>	<p><b>27</b> Top inlet and outlet ports with side gauge port</p>	<p><b>28</b> Side inlet and outlet ports with top gauge port</p>

**INLET MODULE (DIMENSIONS)**

**IN ALL THESE COMMERCIAL CODES PORT SIZE ARE SHOWN ON PAGE 8  
PLEASE LOOK AT THE DIFFERENCES BETWEEN FIXING HOLES**

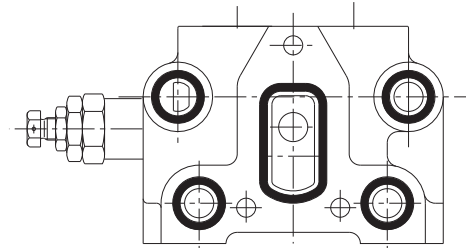
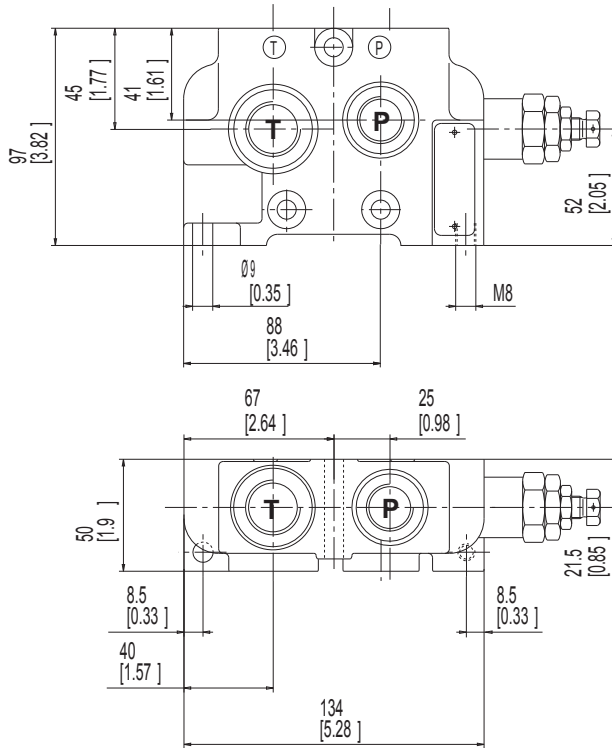

Inlet module: commercial codes  
07 - 08 - 21 - 22 - 27 - 28  
are built always with this dimensions drw.

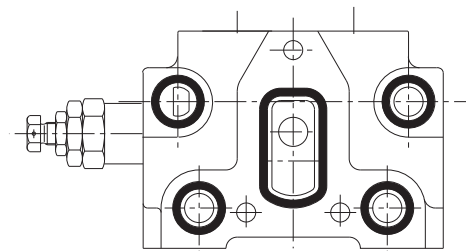
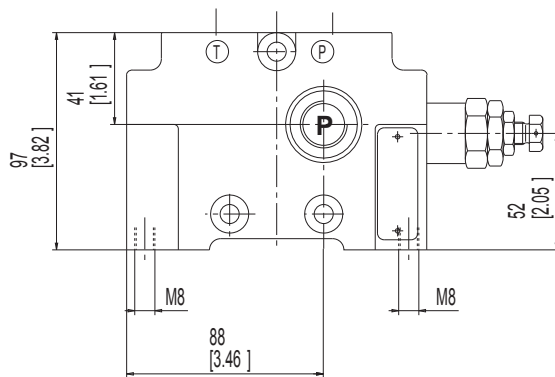

Inlet module: commercial code 23  
is built always with this dimensions drw.  
Moreover in case of venting valve or  
in case you need to put the main relief  
valve on "B" side this is the drawing.

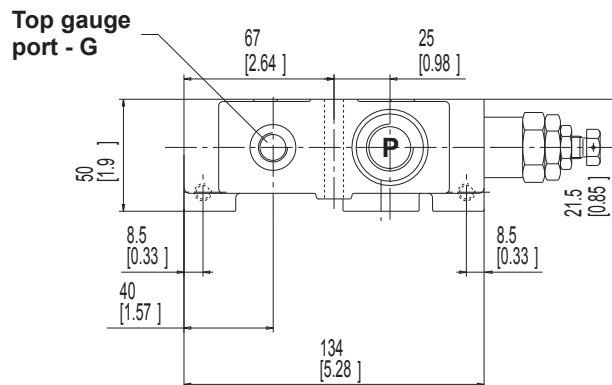

## INLET MODULE WITH PRIORITY FLOW VALVE ADJUSTABLE BY POWER STEERING LOAD

Top outlet port - T (41)  
or  
Top priority flow  
outlet port - TPF (42)

Top inlet port - P

Inlet flow  
gauge port - M

Priority flow  
gauge port - PFGP

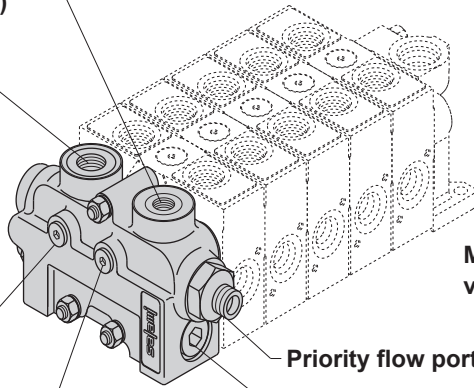

Priority flow port - PF  
Priority flow  
relief valve - PFRV

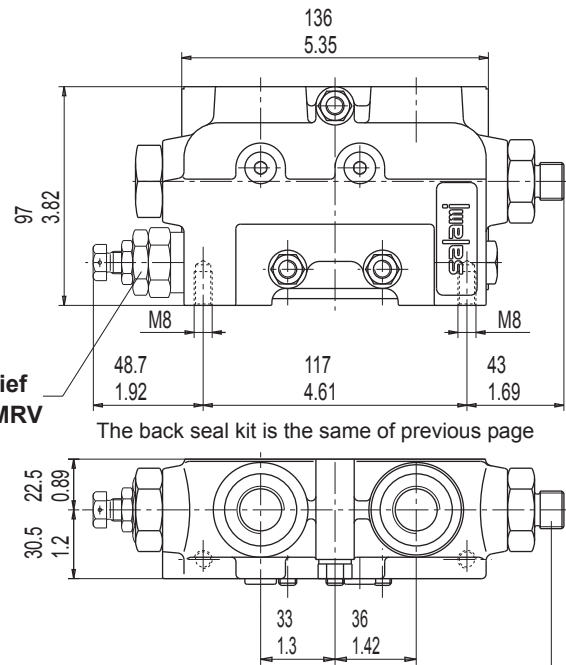

The back seal kit is the same of previous page

Priority flow port is available with  
the following threads:

**BSP (ISO 228) - G 1/4 or G 3/8**  
**SAE UN-UNF (ISO 725) - SAE 4 or SAE 6**

PORT SIZES	P	T	TPF
BSP ISO 228	G 1/2	G 3/4	G 3/8
BSP ISO 228	G 3/4	G 3/4	G 3/8
SAE ISO 176	SAE#10 7/8 - 14 UNF	SAE#10 7/8 - 14 UNF	SAE#6 9/16-18 UNF

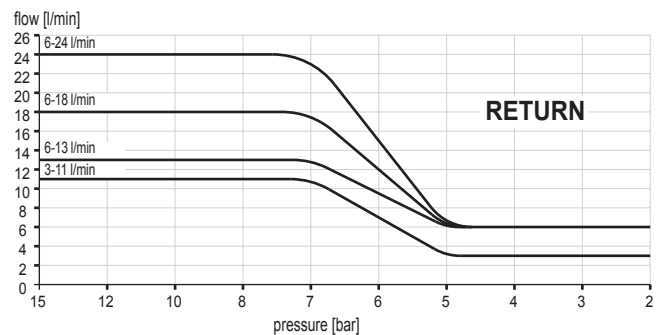
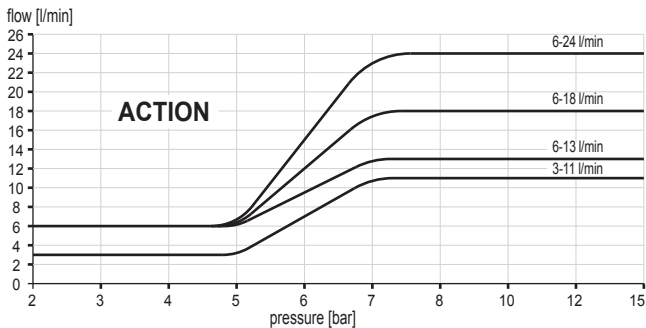

**41**

Top inlet and outlet ports  
priority flow outlet port

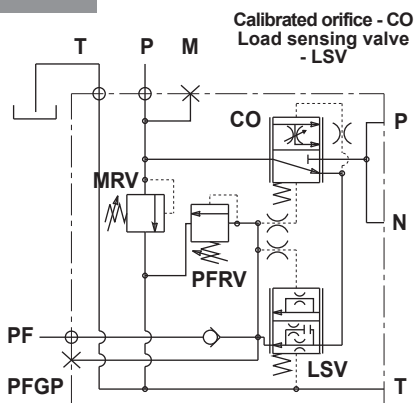

**42**

Top inlet port and  
priority flow outlet port

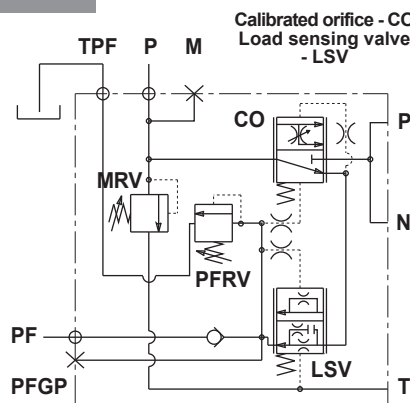

The built-in priority flow valve in this inlet module, supplies the oil to the power steering. This priority valve (PF port in dwg.) supplies always a stand by flow to the steering also when the unit is still. When the steering is operated the flow through the valve can increase or decrease according to the load induced by steering and setting range.

4 setting ranges are available:

- from 3 to 11 l/min - from 0.79 to 2.9 US gpm
- from 6 to 13 l/min - from 1.58 to 3.43 US gpm
- from 6 to 18 l/min - from 1.58 to 4.75 US gpm
- from 6 to 24 l/min - from 1.58 to 6.34 US gpm

## INLET MODULE WITH PRIORITY FLOW VALVE (FIXED PRIORITY FLOW)

Top outlet port - T (41)

or

Top priority flow outlet port - TPF (42)

Top inlet port - P

Inlet flow gauge port - M

Priority flow gauge port - PFGP

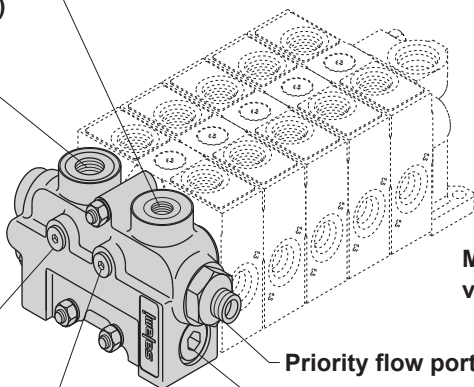

Priority flow port - PF

Priority flow relief valve - PFRV

Main relief valve - MRV

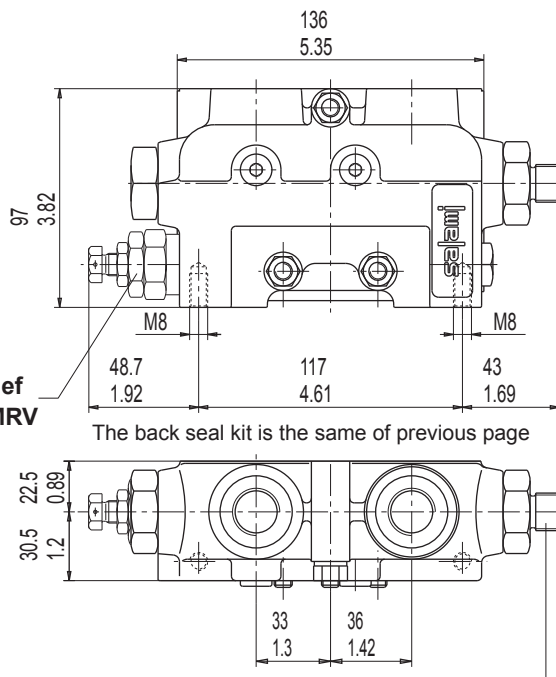

The back seal kit is the same of previous page

PORT SIZES	P	T	TPF
BSP ISO 228	G 1/2	G 3/4	G 3/8
BSP ISO 228	G 3/4	G 3/4	G 3/8
SAE ISO 176	SAE#10 7/8 - 14 UNF	SAE#10 7/8 - 14 UNF	SAE#6 9/16-18 UNF

Priority flow port is available with the following threads:

**BSP (ISO 228) - G 1/4 or G 3/8**  
**SAE UN-UNF (ISO 725) - SAE 4 or SAE 6**

In this valve the pump flow goes trough a calibrated orifice, that allows to keep a priority constant flow value(PF).The exceeding pump flow goes to P line.

Priority flow values available are the following:

- 8 l/min - 2.11 gpm US
- 11 l/min - 2.90 gpm US
- 12.5 l/min - 3.30 gpm US

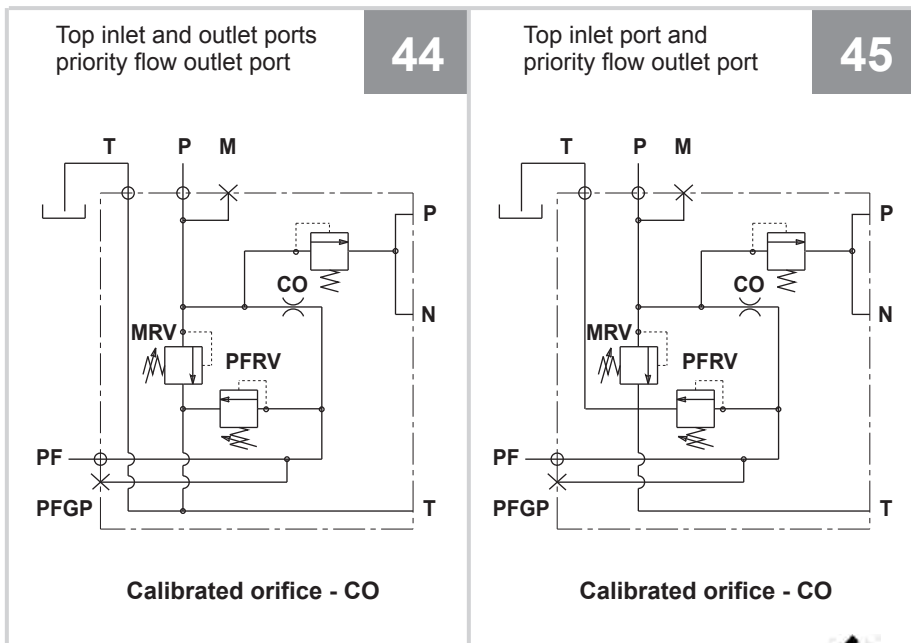

## INLET MODULES

**43**

Inlet module to realize parallel circuit between two different directional control valves. It must be located on the upstream valve.

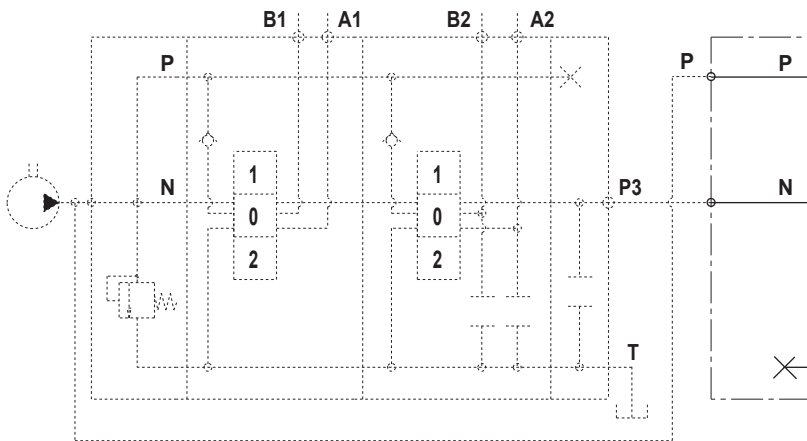

**Pressure port - P** The back seal kit is the same of previous page

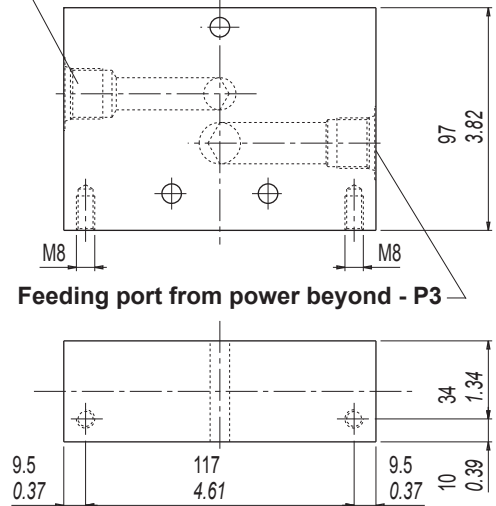

**Feeding port from power beyond - P3**

**51**

Top inlet port with manual pressure switch on "A" side and main relief valve on "B" side (see drw. besides)

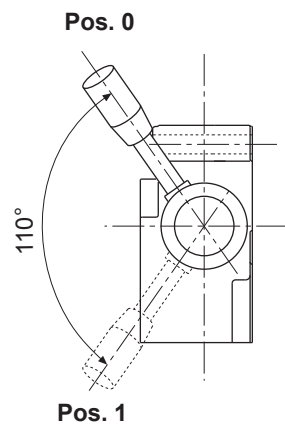
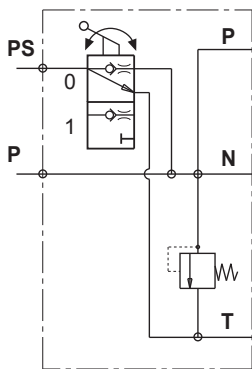

The back seal kit is the same of previous page

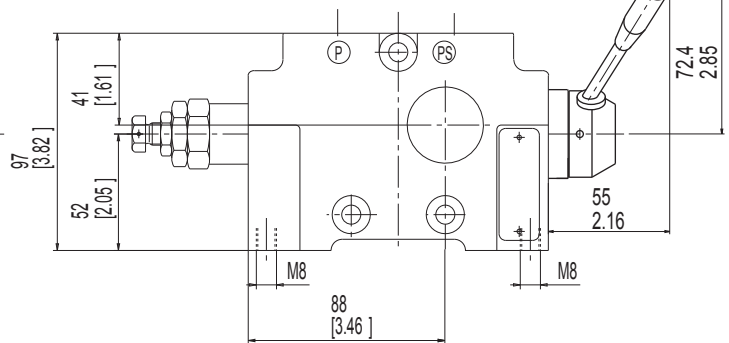

Important:  
in 52 code **P** and **PS** ports are reversed

**Manual pressure switch - PS**

**Top inlet port - P**

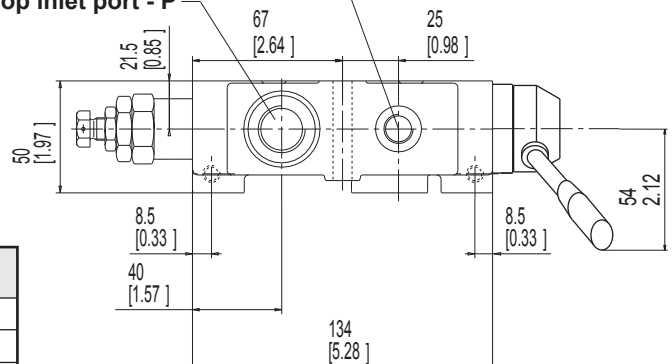

**52**

Top inlet port with manual pressure switch on "B" side and main relief valve on "A" side (same hydraulic circuit)

P port size see page 8

PORT SIZES	PS
BSP ISO 228	G 3/8
METRIC ISO 262	G 3/8
SAE ISO 176	SAE#6 9/16-18 UNF



**SINGLE AND DOUBLE WORKING MODULE (PARALLEL CIRCUIT)**

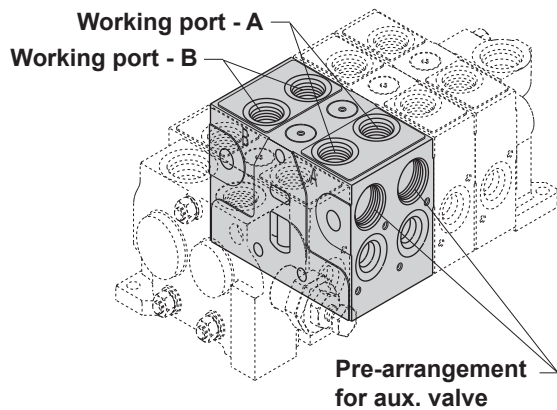
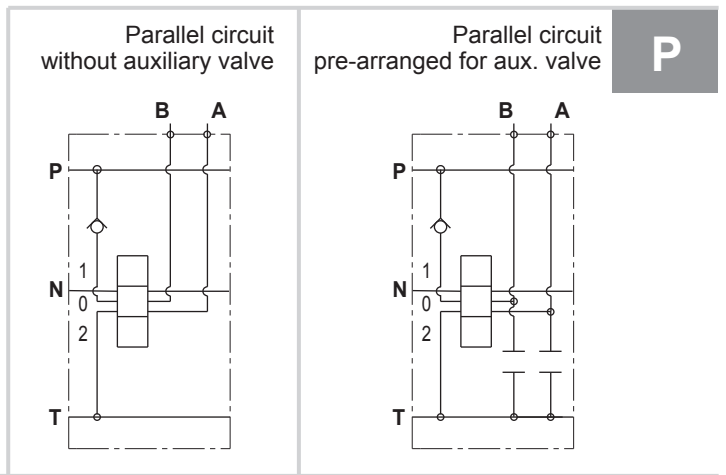
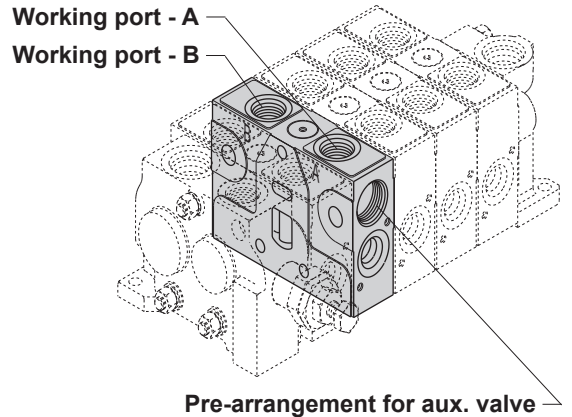
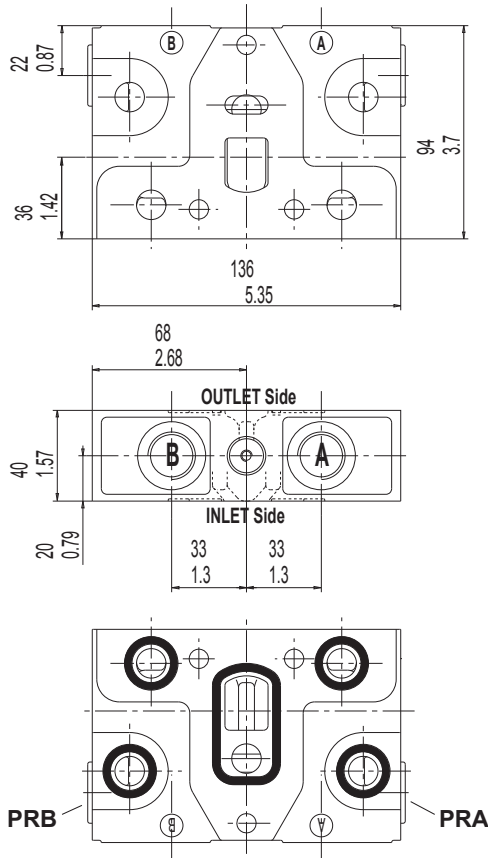

In phase of order you must specify single or double working module parallel circuit.

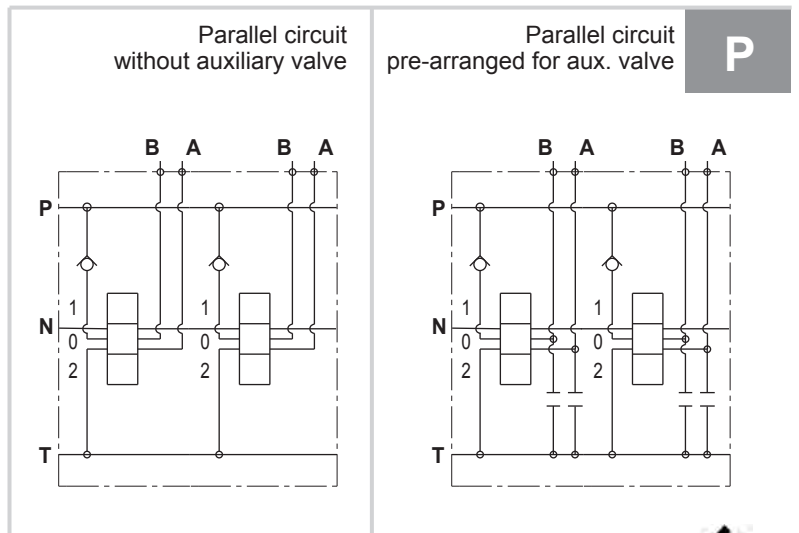
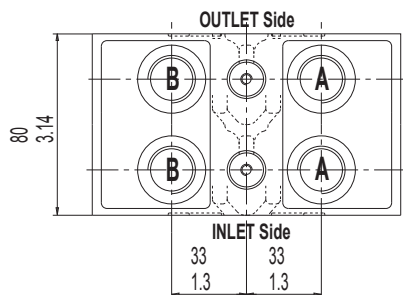

## WORKING MODULE WITH ADJUSTABLE OR FIXED PRIORITY FLOW VALVE PRESSURE COMPENSATED

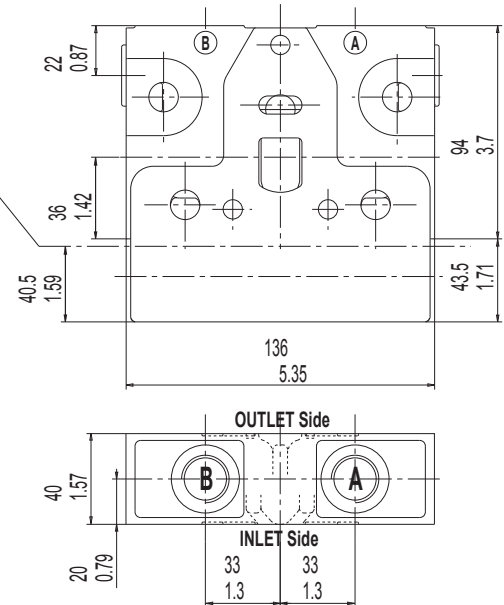
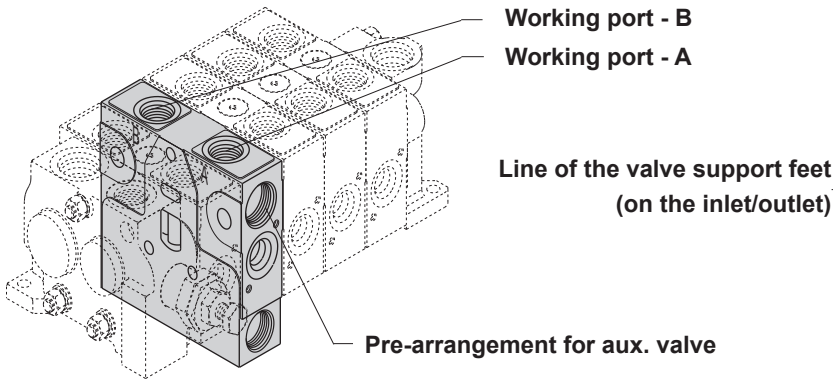

The back seal kit is the same of previous page

Important: the handle flow regulation is always available on "A" side  
Available with or without load check valve - **LCV**

**R**

Fixed priority flow  
pre-arranged for aux. valve

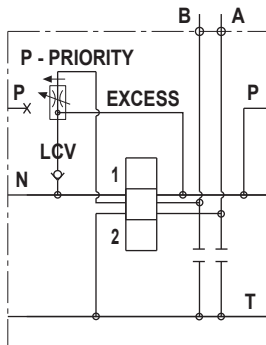

Fixed priority flow  
without aux. valve

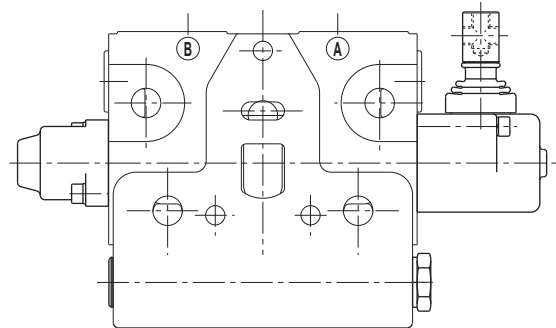
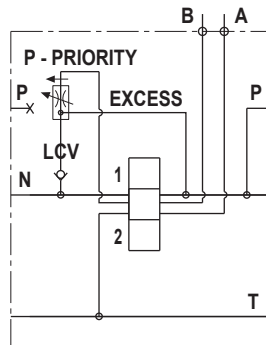

Available values of fixed flow

l/min	4.5	6	9	10	16
US gpm	1.9	1.6	2.4	2.6	4.2

**R**

Adjustable priority flow  
pre-arranged for aux. valve

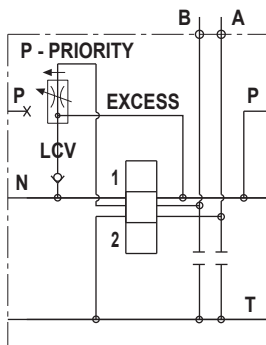

Adjustable priority flow  
without aux. valve

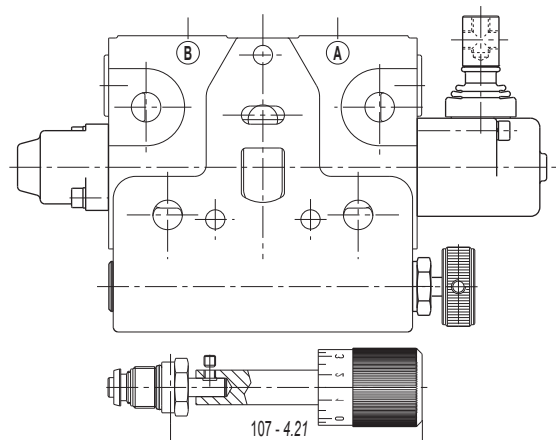
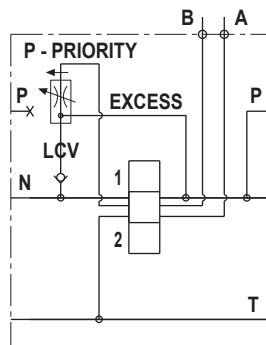

Adjustable flow with **LCV** : 45 l/min - 12 US gpm  
Adjustable flow without **LCV** : 60 l/min - 16 US gpm

**SINGLE AND DOUBLE WORKING MODULE (SERIES CIRCUIT)**

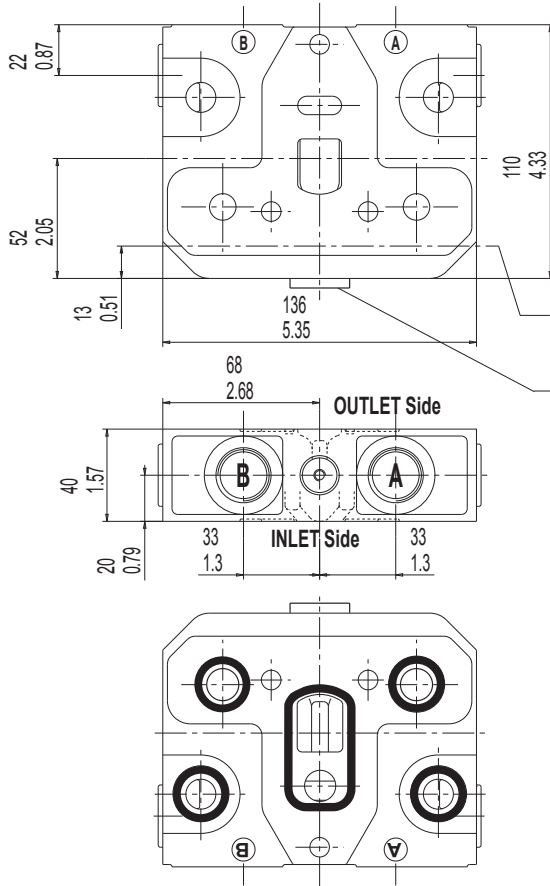

The series circuit working module is available with or without secondary load check valve on series gallery.  
**With spools commercial codes: 02 - 03 - 04 - 11 - 12**  
secondary load check valve on the series line, is always necessary

Line of the valve support feet (on the inlet/outlet)

Load check valve on series line

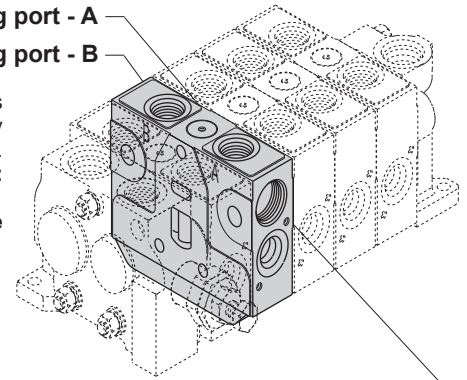

Pre-arrangement for aux. valve

Series circuit without auxiliary valve

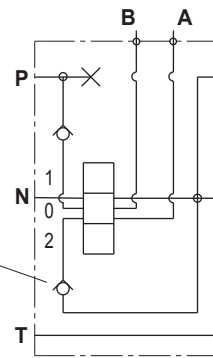

Series circuit pre-arranged for aux. valve

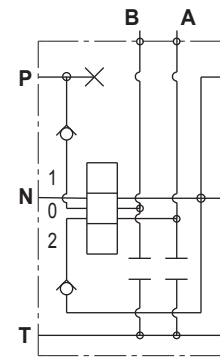

**S**

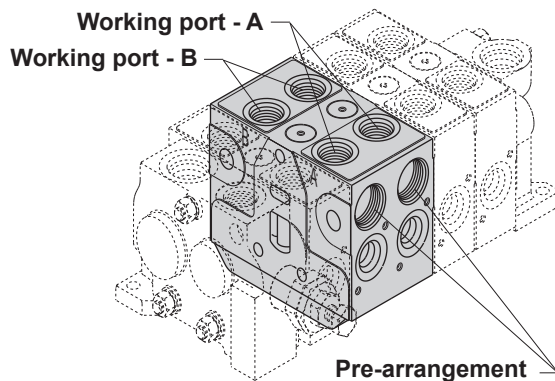

Pre-arrangement for aux. valve

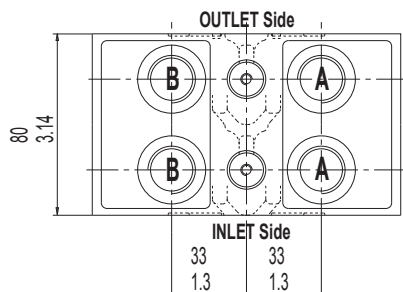

In phase of order you must specify single or double working module series circuit.  
Available only for quantity, please contact our sales dept.

Series circuit without auxiliary valve

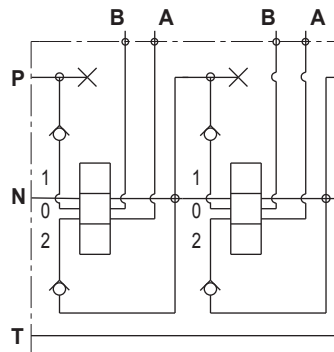

Series circuit pre-arranged for aux. valve

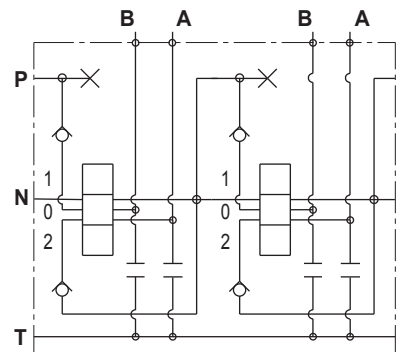

**S**

### WORKING MODULE (TANDEM CIRCUIT)

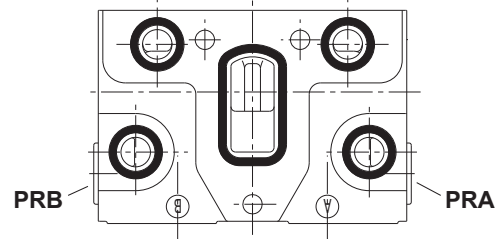
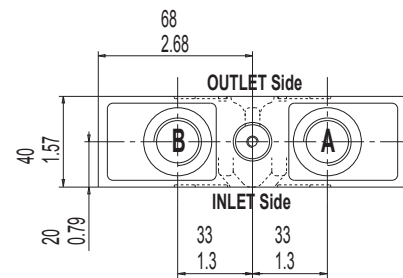
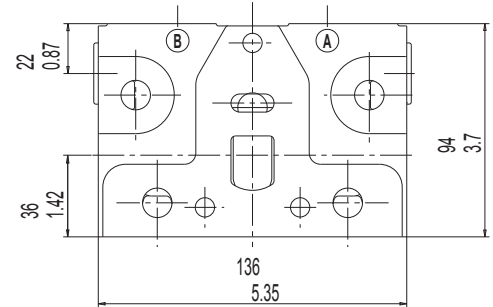
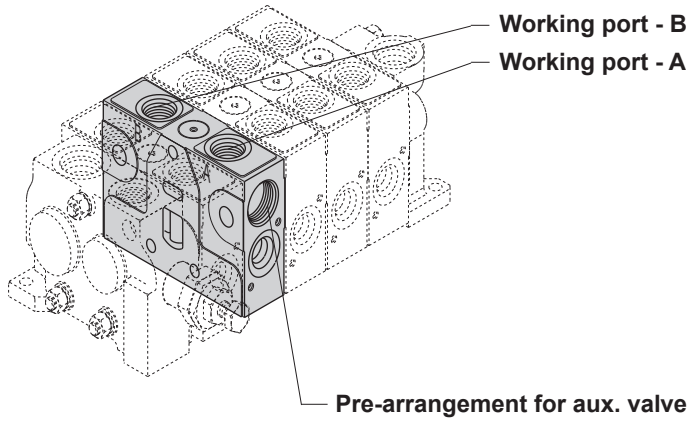

**T**

Tandem circuit  
without auxiliary valve

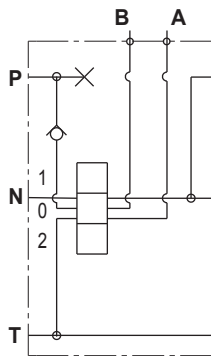

Tandem circuit  
pre-arranged for aux. valve

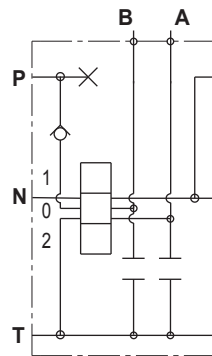

**MID INLET MODULE (HYDRAULIC CIRCUITS)**

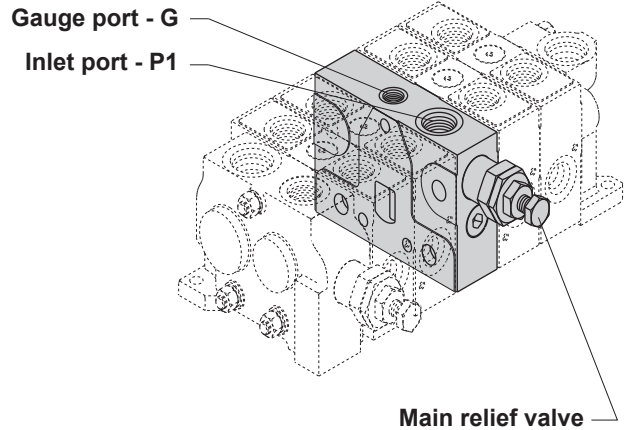
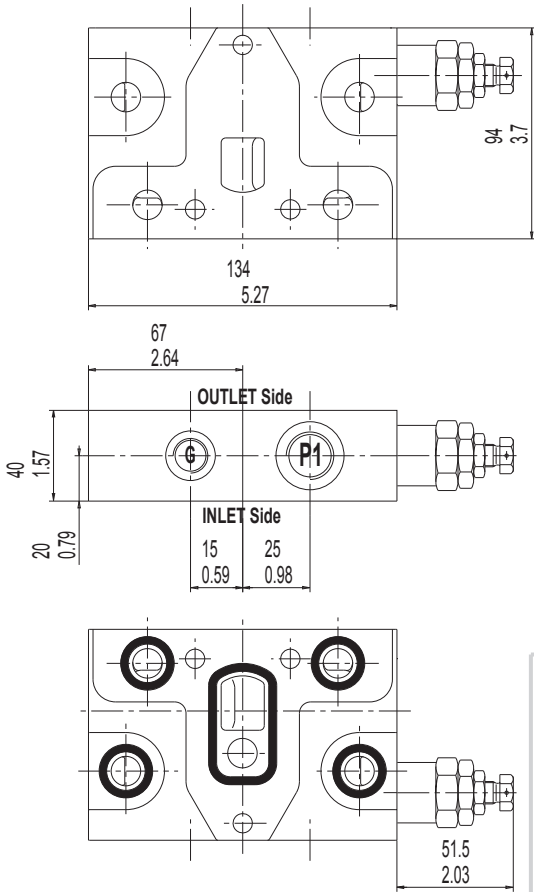

Gauge port is available with the following threads:  
**BSP (ISO 228) - G 1/4**  
**SAE UN-UNF (ISO725) - SAE 4**

Mid inlet for second pump with combining flows without main relief valve

**12**

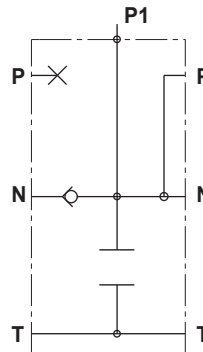

Mid inlet for second pump with combining flows and main relief valve

**11**

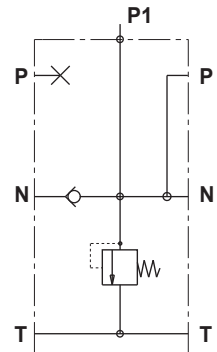

Mid outlet

**19**

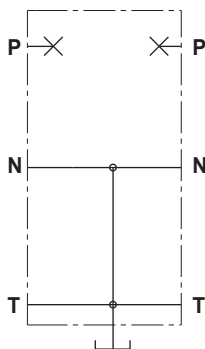

Mid inlet for second pump with split flows and main relief valve + gauge port

**14**

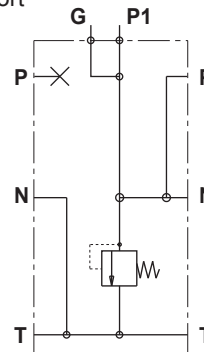

Mid inlet for second pump with split flows and main relief valve

**13**

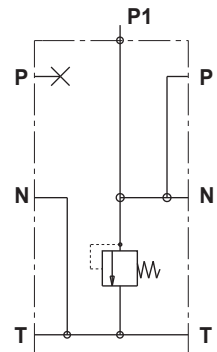

## OUTLET MODULE (HYDRAULIC CIRCUITS)

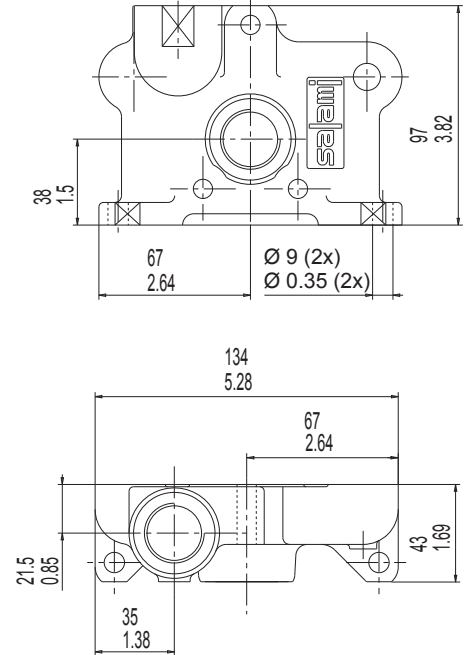
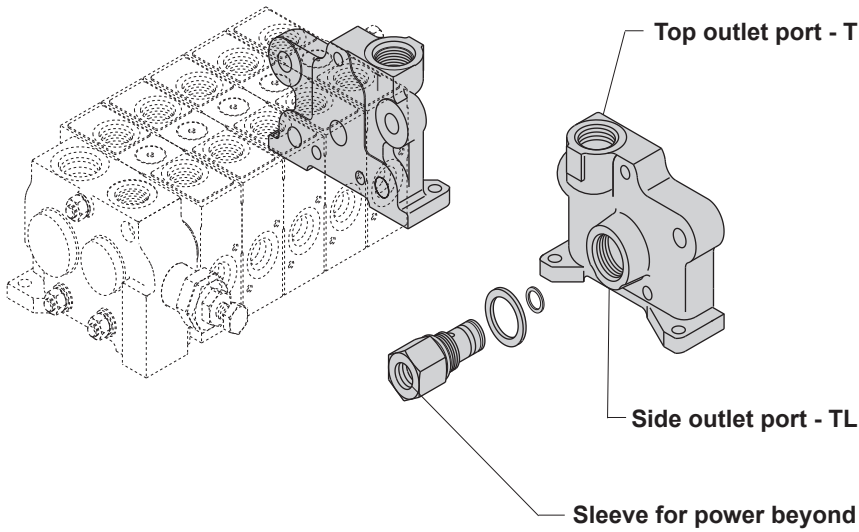

<p><b>U0</b> Without port</p>	<p><b>U1</b> Top port</p>	<p><b>U2</b> Top and side ports</p>			
<p><b>U3</b> Side port top port plugged</p>	<p><b>U4</b> Top port side port plugged</p>	<p><b>U5</b> Power beyond configuration (side P3)</p>	<p><b>U7</b> Closed center circuit configuration</p>	<p><b>U8</b></p> <p>Outlet type necessary for electro-hydraulic controls, please go to page 36 to see the drawing and hydraulic scheme.</p>	

**ASSEMBLING TIE RODS**

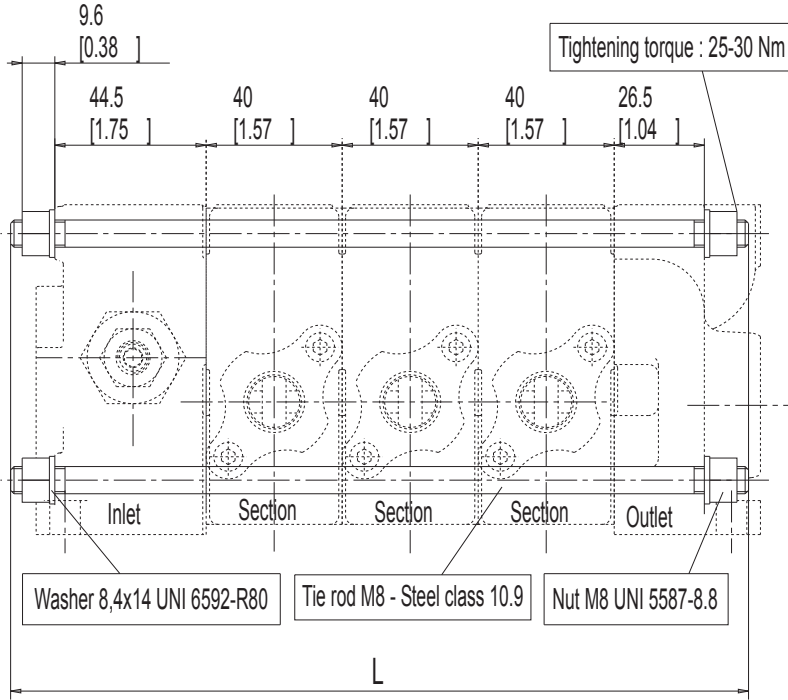

N° of sections	Length L	
	mm.	[inch]
1	137	[5.39]
2	177	[6.97]
3	217	[8.54]
4	257	[10.12]
5	297	[11.69]
6	337	[13.27]
7	377	[14.84]
8	417	[16.42]

Example of assembling of 2 working modules + inlet and outlet modules with tie-rods and side seal kits

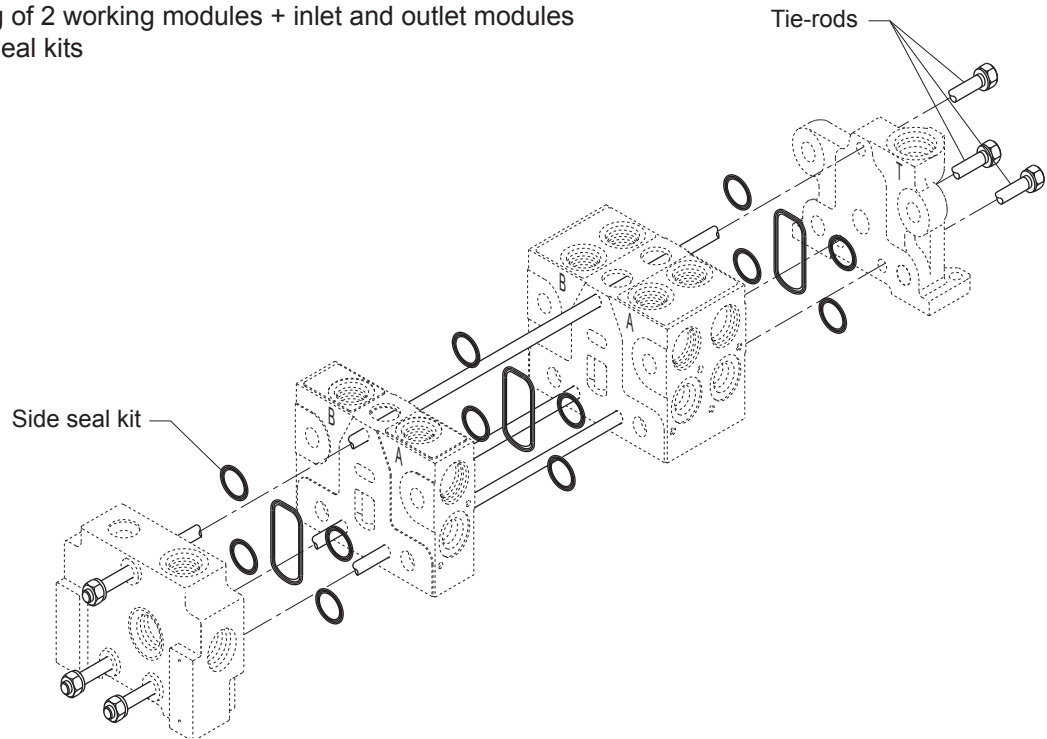

### CIRCUIT AND SPOOL TYPES

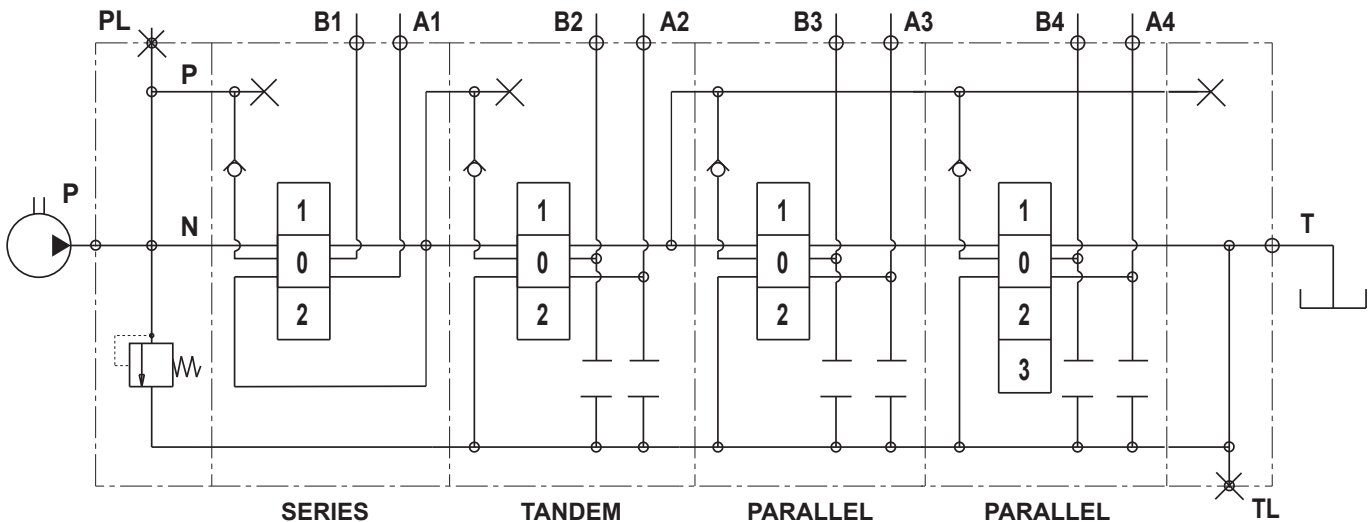

The circuits available are:

parallel type, series type, tandem type as shown in the picture above (tandem type with priority flow valve is available too, see page 16). You can have main relief valve or venting valve in the inlet (see page 14), the working sections can have pre-arrangement for auxiliary valves or not (you can mount venting valve too).

The spools can be 3 or 4 positions (as shown here below) moreover VD8A is available for power beyond just adding a sleeve (see page 20).

As you can read at page 44, the spools can be types "A" nominal flow or "C" 2/3 of nominal flow.

01		Double acting spool	Double acting motor spool		02
03		Double acting motor spool ("B" port blocked)	Double acting motor spool ("A" port blocked)		04
05		Single acting spool "A" working port	Single acting spool "B" working port		06



<p><b>11</b></p>	<p>Double acting spool with float function in 3rd position (spool in)</p>	<p>Double acting spool with float function in 3rd position (spool out)</p>	<p><b>12</b></p>
<p><b>13</b></p>	<p>Double acting spool with regenerative function in 3rd position (spool in)</p> <p>With this type of spool a special machining of the body is required</p>		
<p><b>17</b></p>	<p>Double acting spool with regenerative function in position 2 (spool in)</p> <p>With this type of spool a special machining of the body is required</p>	<p>Double acting spool with regenerative function in position 1 (spool out)</p> <p>With this type of spool a special machining of the body is required</p>	<p><b>18</b></p>
<p><b>52</b></p>	<p>Over center double acting spool "A" working port</p>	<p>Over center double acting spool "B" working port</p>	<p><b>53</b></p>
<p><b>54</b></p>	<p>Over center double acting spool "A and B" working ports</p>		

Salami standard spools have the ends as shown in this drawing. These ends spool are necessary to join it the controls and the positionings. With direct electric and hydraulic controls the ends spool are different as you can see at pages 33 and 34.

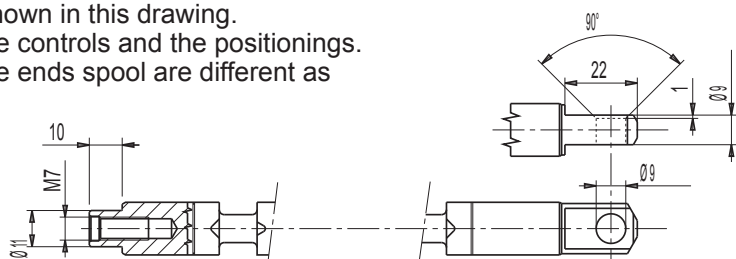

## MAIN RELIEF VALVES

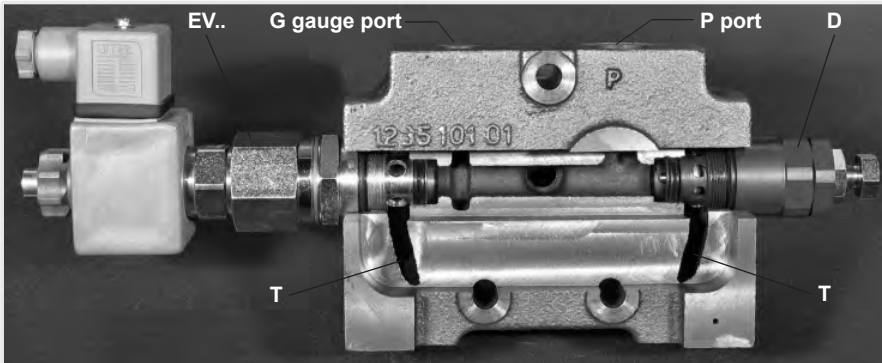

Max tightening torque:  
 wrench 13 - 24 Nm  
 wrench 17 - 27 Nm  
 wrench 25 - 35 Nm  
 wrench 27 - 40 Nm  
 wrench 30 - 75 Nm  
 Allen wrench 8 - 27 Nm



The main relief valve can be mounted on "A" or "B" side, in case of venting valve this is at the opposite side of the main relief. All the testing values of this page have been obtained with nominal flow of 50 L/min - 13.21 gpm, viscosity 16cST and oil temperature 50°C - 122°F.

**D**

**MAIN RELIEF VALVE DIRECT OPERATED**  
 (setting range from 25 to 250 bar - 362 to 3625 psi)

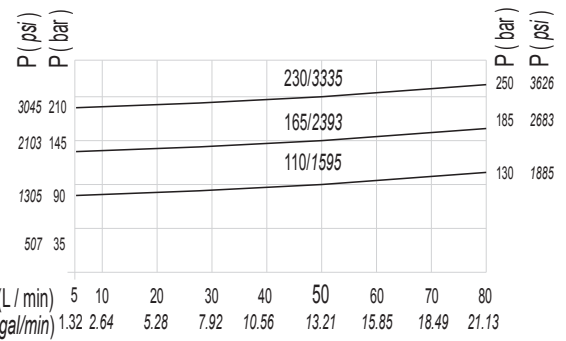
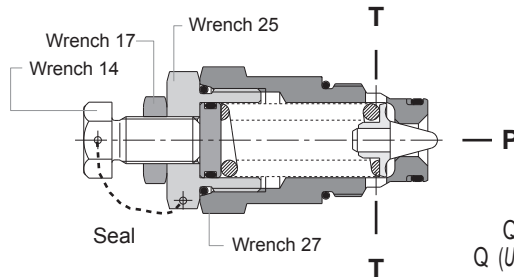
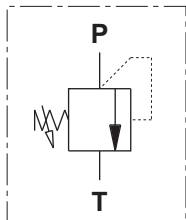

**P**

**MAIN RELIEF VALVE PILOT OPERATED**  
 (setting range from 25 to 280 bar - 362 to 4061 psi) first spring  
 (setting range from 100 to 400 bar - 1450 to 5800 psi) second spring

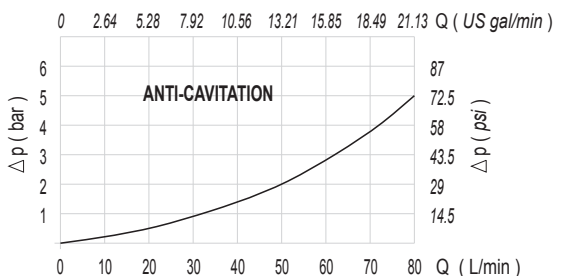
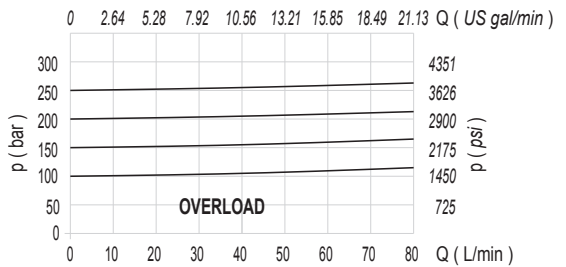
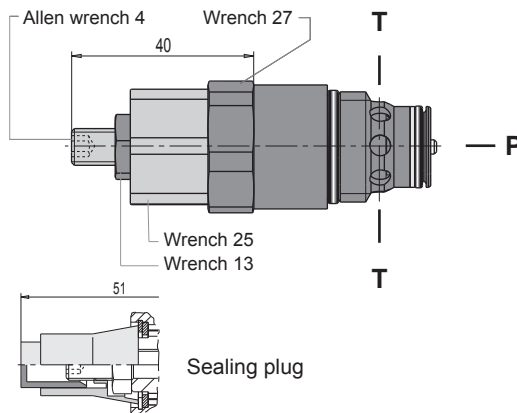
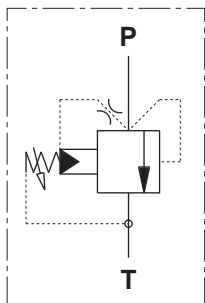

Both valves D and P are adjustable without oil leaking. Further more, both have a security device to avoid valve sticking

**W**

**PLUG FOR MAIN RELIEF SEAT WITHOUT VALVE**

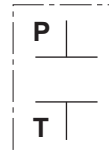
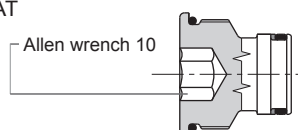

## VENTING VALVES (AVAILABLE AS AUXILIARY VALVE TOO)

This valve is located in the same cavity of the main relief valve, but or at the opposite side or without main relief. All the commercial codes in this page can be mounted as auxiliary valve too. For all the test conditions, please refer you to page 24.

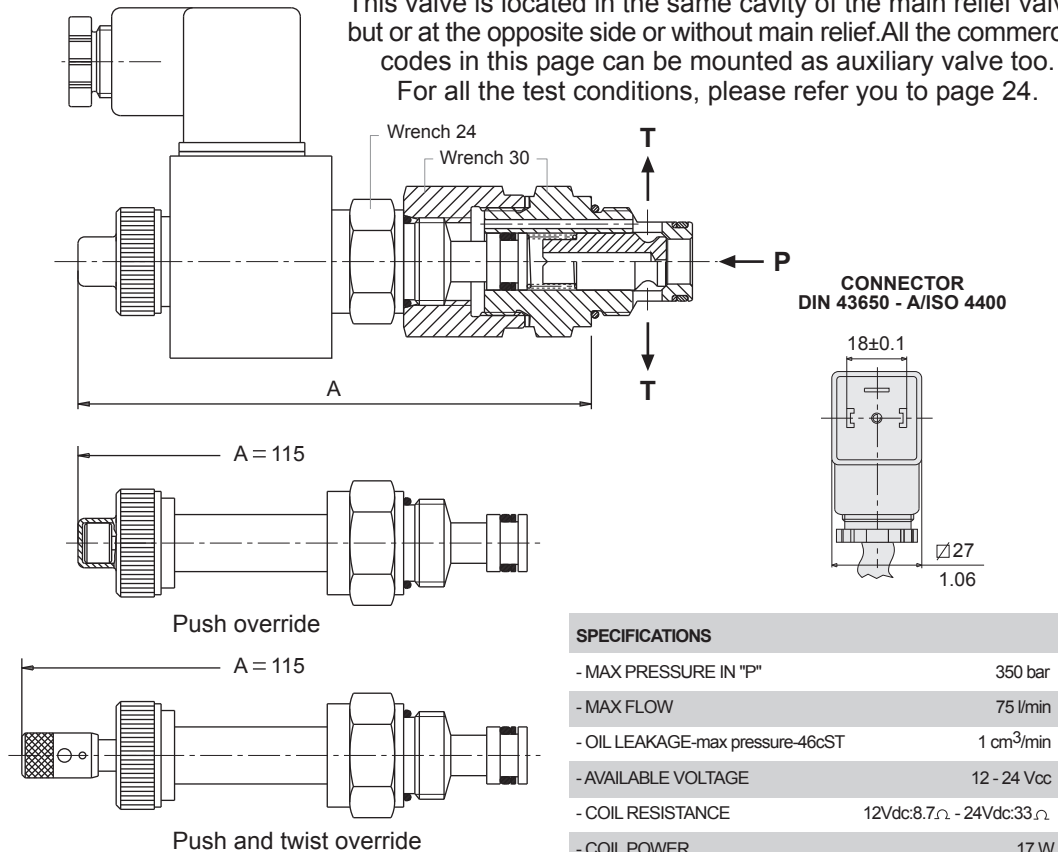

**EV1**

12 Vdc - Normally opened  
Push override

**EV2**

24 Vdc - Normally opened  
Push override

**EV3**

12 Vdc - Normally closed  
Without override

**EV4**

24 Vdc - Normally closed  
Without override

**EV5**

12 Vdc - Normally opened  
Push and twist override

**EV6**

24 Vdc - Normally opened  
Push and twist override

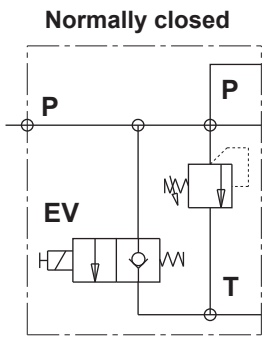
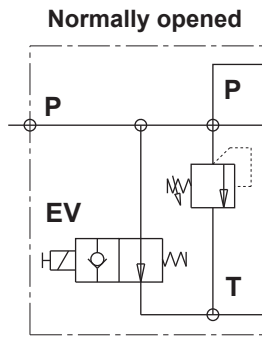
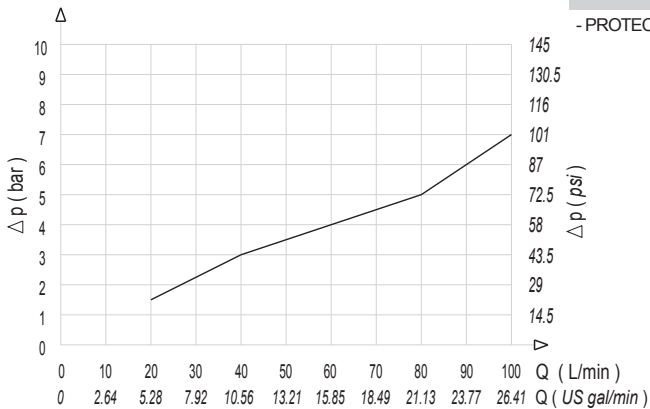

A available threads	
M10 x 1	SAE 6

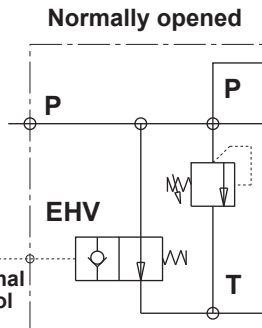
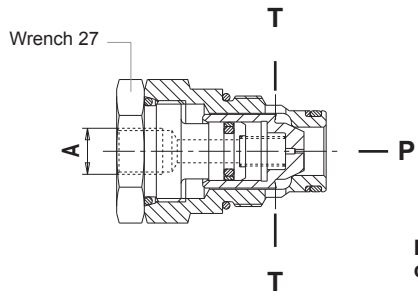

**EHV**

External piloted  
venting valve

## AUXILIARY VALVES

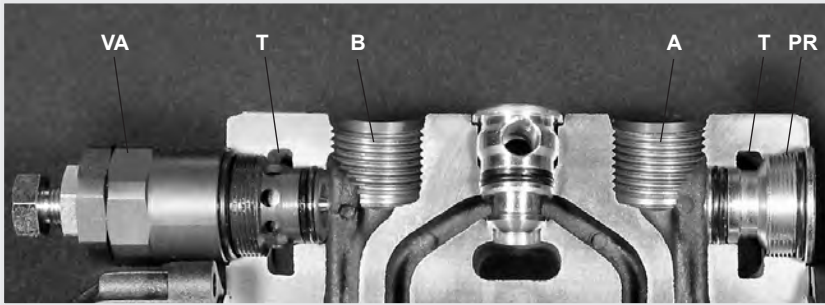

This picture shows the position of the auxiliary valves. For the tightening torque please see page 24.

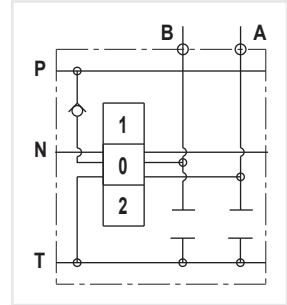

### VA

**OVERLOAD VALVE**  
(setting range from 25 to 250 bar - 362 to 3625 psi)

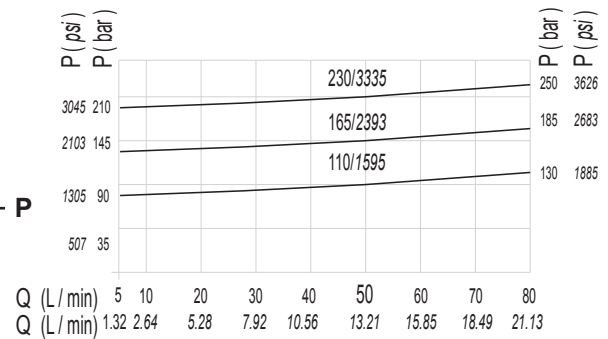
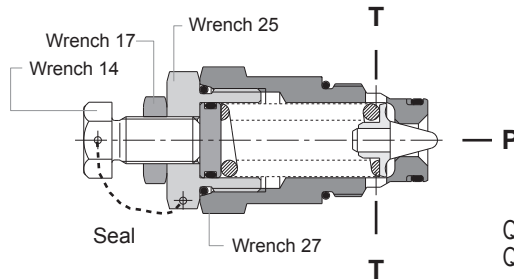
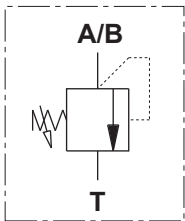

### AR

**OVERLOAD AND ANTI-CAVITATION VALVE**  
(setting range from 25 to 280 bar - 362 to 4061 psi) first spring  
(setting range from 100 to 400 bar - 1450 to 5800 psi) second spring

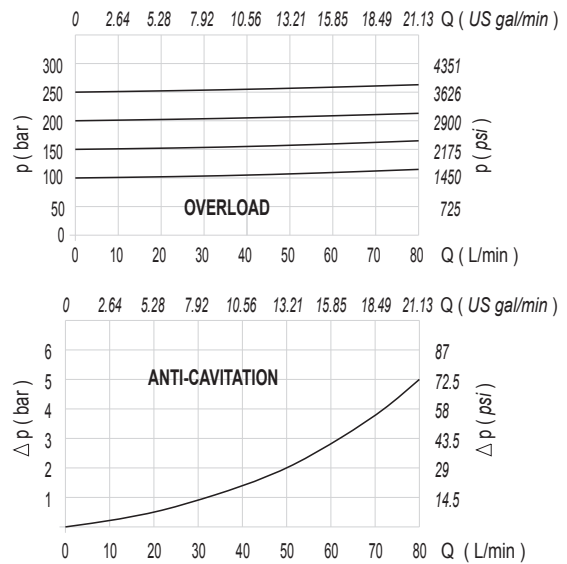
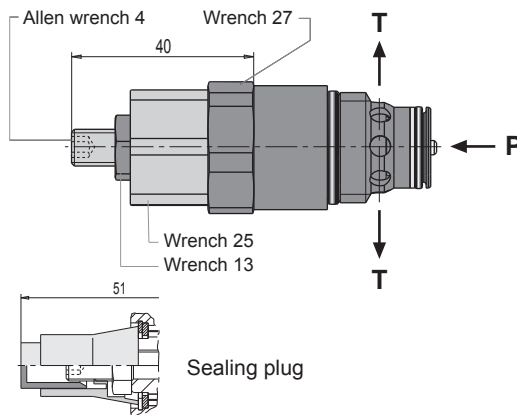
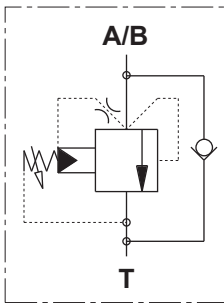

Both valves AR and VR are adjustable without oil leaking. Further more, both have a security device to avoid valve sticking.

### VR

**ANTI-CAVITATION VALVE**

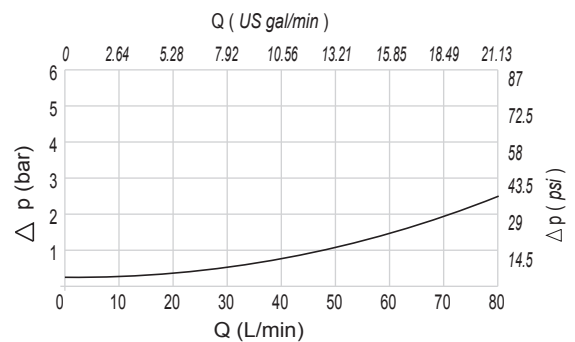
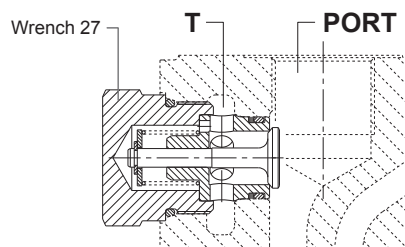
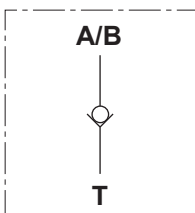

**AUXILIARY VALVES**

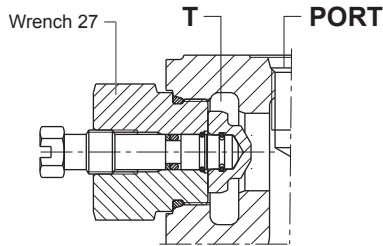

**OPENED**

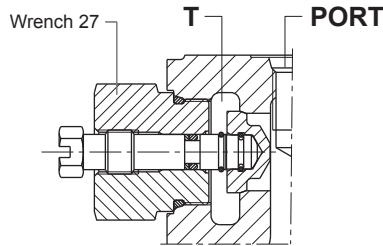
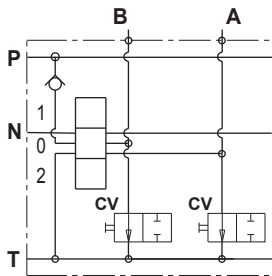

**CLOSED**

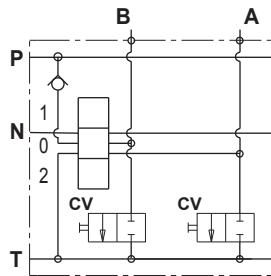

**CV**

**CONVERSION VALVE**

The conversion valve **CV** allows to obtain single acting function starting from double acting spool just connecting the port to tank. For example starting from a double acting spool to obtain a single acting "A" port function, we must open the **CV** valve sending "B" port to tank line.

**PR**

**PLUG FOR CAVITY**

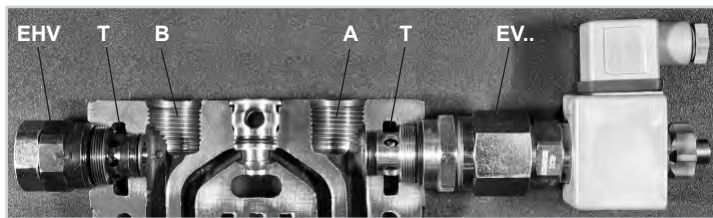
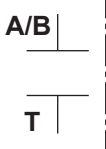
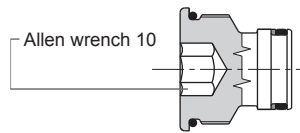

**Electric venting valve**

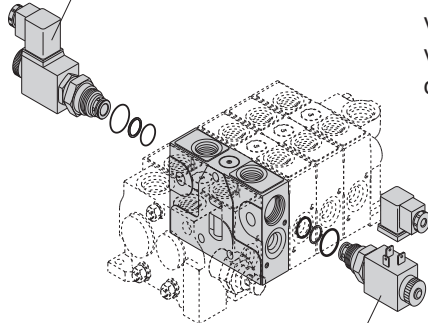

**Electric venting valve**

As you can read at page 25, all venting valve are also available as auxiliary venting valve, the commercial codes and technical data are the same of page 25.

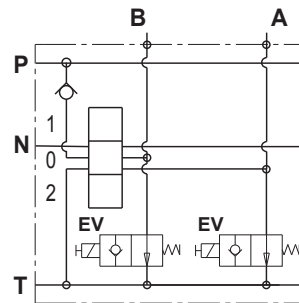

**EV..**

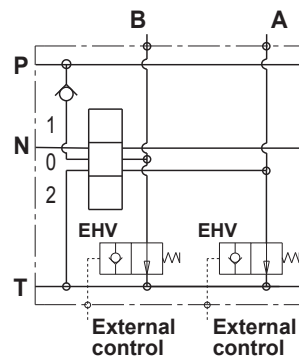

**EHV**

## OTHER VALVES

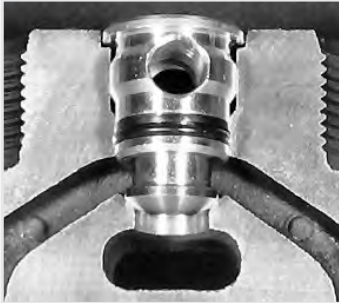

This is the load check valve VU which is built in every working module between ports and you need not to specify in phase of ordering because it is part of the module.  
In the series circuit working module you can have another load check valve on the series line as you can see in the drawing of page 17.

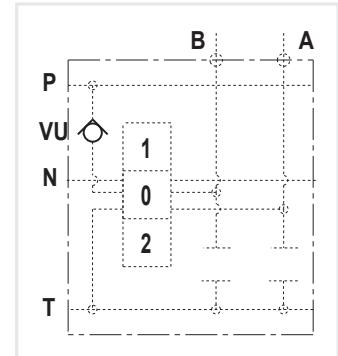

### SP

Flow restrictor P → A/B

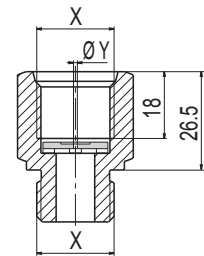
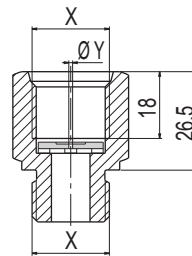
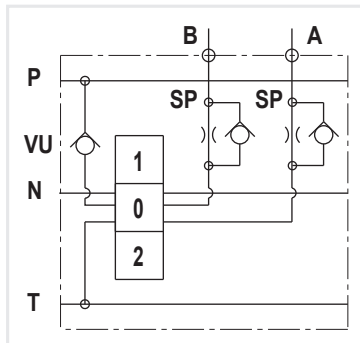

### ST

Flow restrictor A/B → T

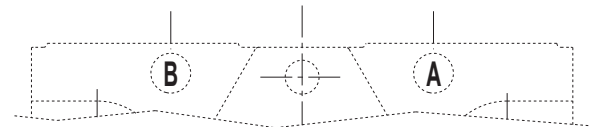
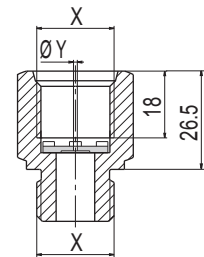
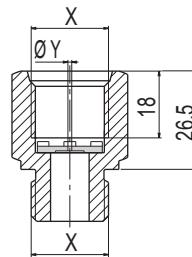
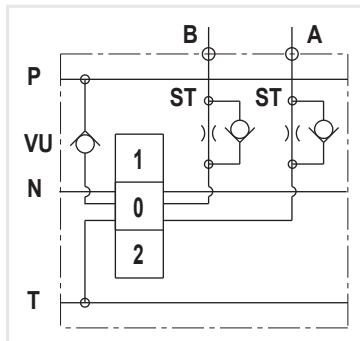

For tightening torque, please refer you to page 5.

X available threads			φ Y available measures					
*M22 x 1.5	SAE 10	G 1/2	φ 2	φ 2.5	φ 2.75	φ 3	φ 3.25	φ 4.5

\*Available for quantity, please contact our sales dept.



**SPOOL CONTROLS AND SPOOL POSITIONINGS**

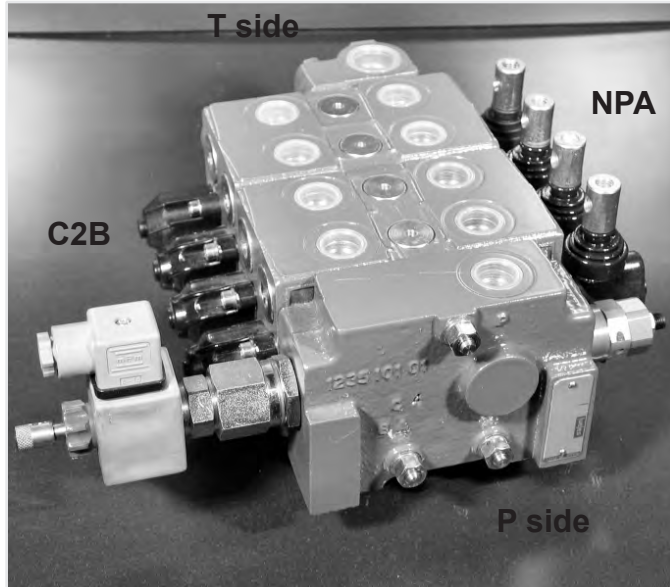

This picture shows the VD8A assembled, in this case you have a manual control "NP" on A side and a spring return in neutral position "C2" on B side. In this case the manual control "NP" is used directly to have the spool movement, in other case, for example with electro-hydraulic control, there is only a safety lever. Considering that VD8A is a simmetrical valve, all spool controls and positionings can be placed on both sides A or B. In case of hydraulic kick-out "G2 - G4 - G5" and with spools types 13 - 17 - 18, you can also decide A or B side but after that this is the final position because with this type of control and spools the working module have a special machining.

In this and following pages you can find all spool controls and spool positionings, they are all assembled with socket hexagon head screw or in some case hexagon head screw:

**M5 x 0.8 with tightening torque of 4.5 ± 0.5 Nm.**

The drw. here below show the reference to fix A and B side from the point of view of the operator.

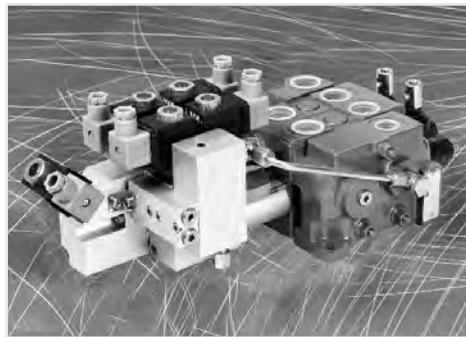

**VD8A - 2 working modules  
with electro-hydraulic controls  
H1/H2 - H3/H4**

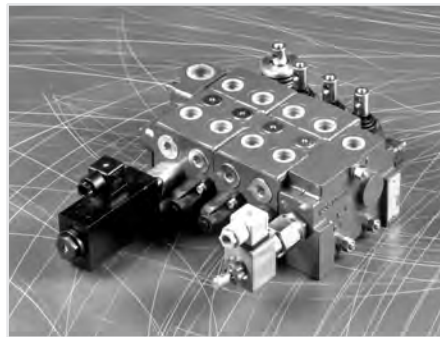

**VD8A - 4 working modules (2 bi-blocks)  
with miscellaneous of controls  
NP - E7/E8 - C2 and EV on inlet m.**

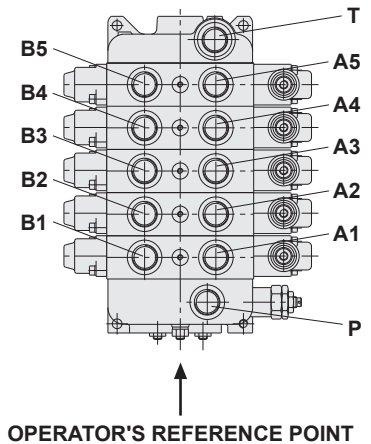

**VD8A - 4 working modules  
with electro-pneumatic control P1/P2**



**VD8A - 4 working modules  
(2 bi-blocks) with hydraulic prop.  
control IP**

## SPOOL CONTROLS

### SL

Without lever box

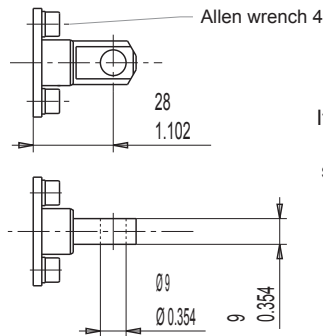

Male version

If you order SL we will supply the male version, which is the standard. For the female version please specify it when ordering.

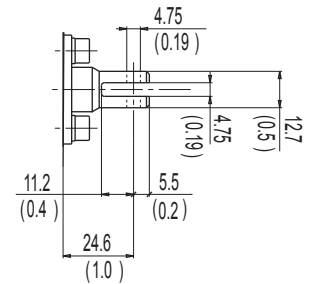

**Female version**  
available for spools from 01 to 06  
for the other spools please get in touch  
with our sales dept.

### NL

Low effort  
protected lever

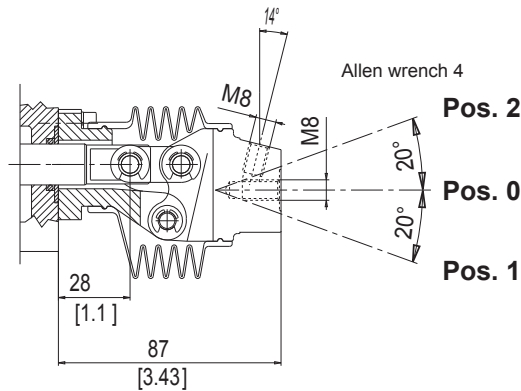

This lever can be assembled turned of 180°

### NP

Standard  
protected lever

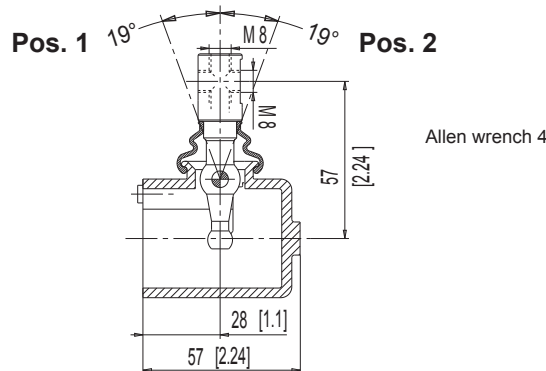

This lever can be assembled turned of 180°  
In case of auxiliary valve it must be assembled  
turned of 180° with reference to this axis

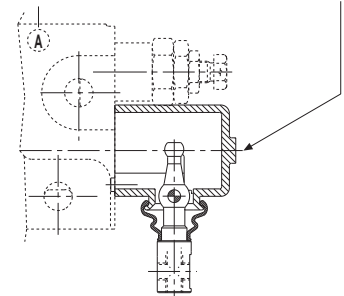

### MP

Protected clamp  
lever

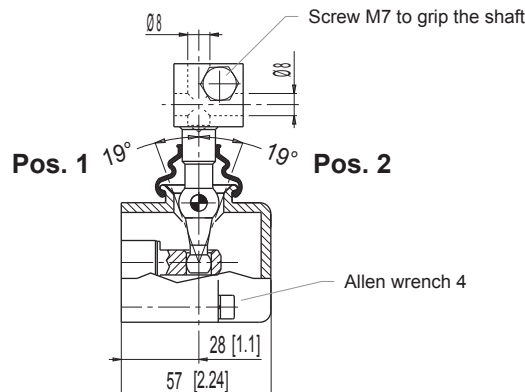

This lever can be assembled turned of 180°  
In case of auxiliary valve it must be assembled  
turned of 180° with reference to this axis

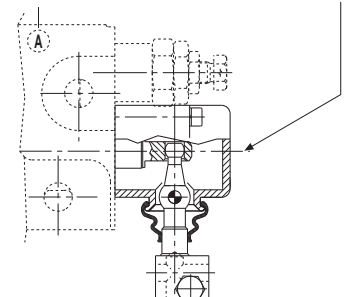



**SS**

This lever can be assembled turned of 180°  
In case of auxiliary valve it must be assembled  
turned of 180° with reference to this axis

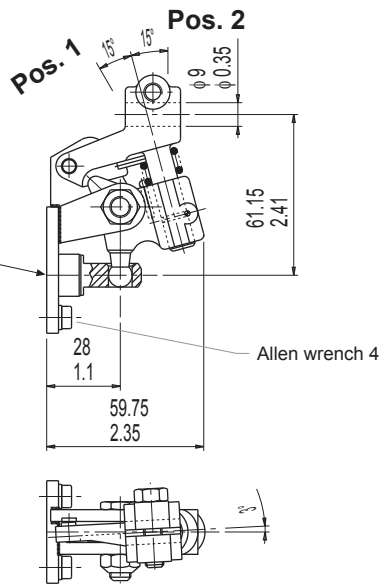

Necessary side shift to release  
the security locking

Lever with security locking in neutral pos.  
Side shift to unlock

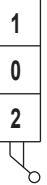

This lever with security locking in neutral pos.  
has been created to avoid its accidental  
movement caused by vibrations of the  
application.

**FL**

This lever can be assembled turned of 180°  
In case of auxiliary valve it must be assembled  
turned of 180° with reference to this axis

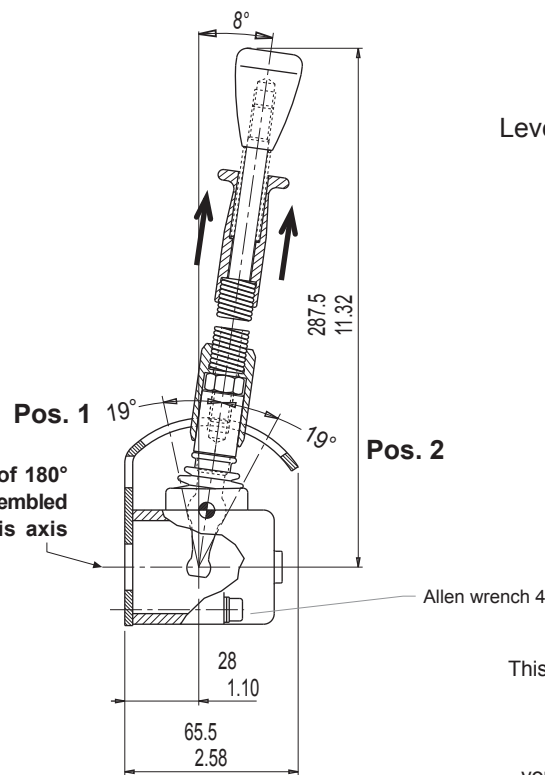

Lever with security locking in neutral pos.  
Pull the grip to unlock.

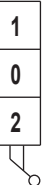

This lever with security locking in neutral has been  
created to avoid its accidental movement  
caused by vibrations of the application.  
Before to put the lever in positions 1 and 2  
you must release it by pulling it as per the arrows

## L2

Cross lever for 2 spools  
fulcrum on down-stream spool

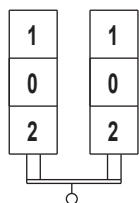

## L1

Cross lever for 2 spools  
fulcrum on up-stream spool

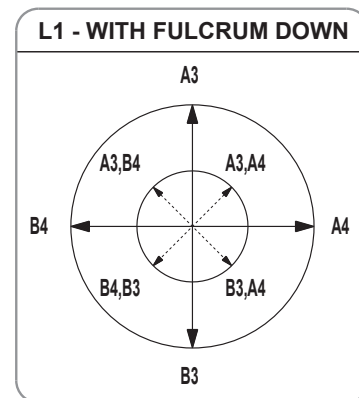
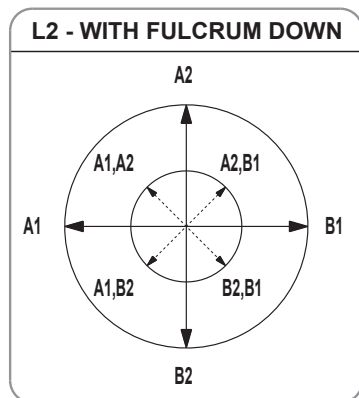
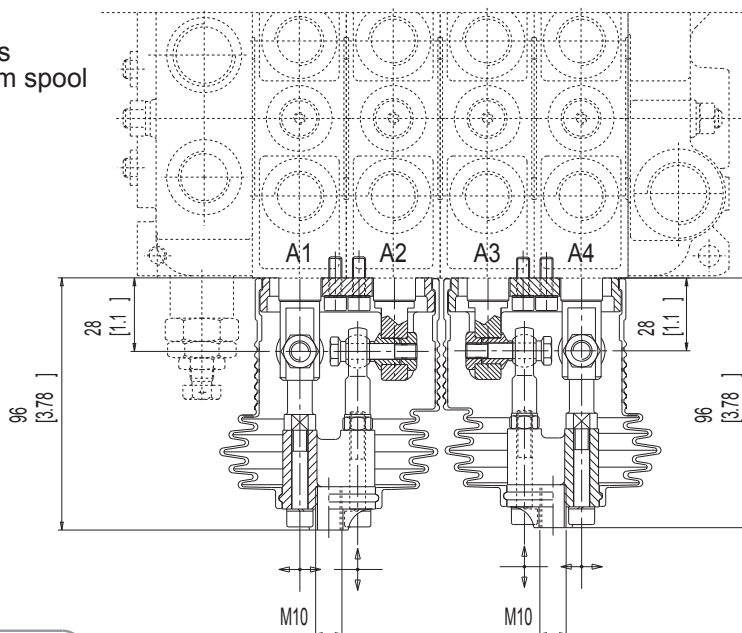
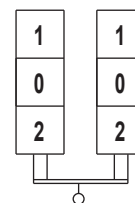

## STANDARD SHAFTS

For different diameter and/or length, please get in touch with our sales dept.

Shaft with ergonomic knob  
for cross lever L1/L2  
**R202 8996 0**

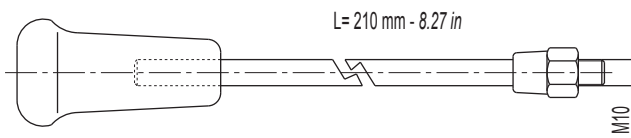

Shaft with threaded end  
**R202 9018 0**

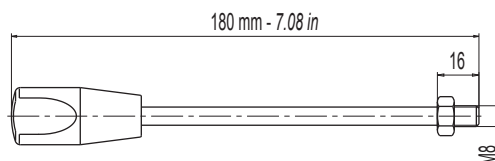

Shaft for clamp lever  
**R202 8839 0**

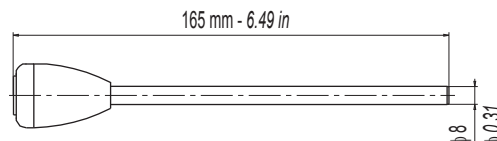

# DIRECTIONAL CONTROL VALVE SECTIONAL TYPE

# VD8A

**D1**

Devices for cable remote control for both the ends of spool.  
For more details about cables, please consult our catalogue  
cable remote controls.

**TC**

End spool with threaded hole M7  
Positionings side

End spool with hole  $\phi$  9 mm.  
Controls side

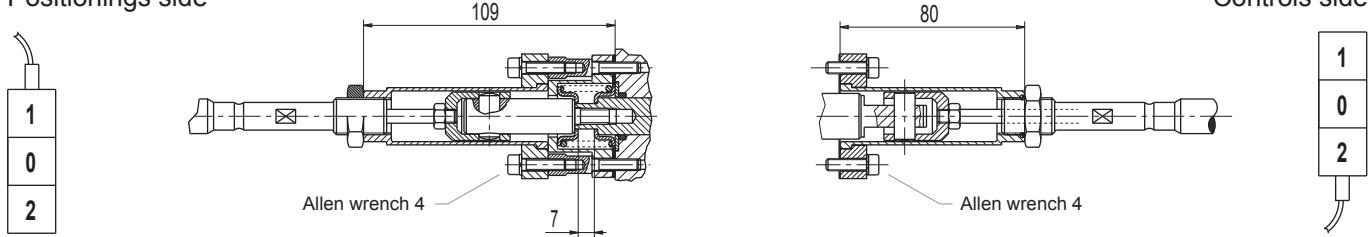

**E1**

**Working conditions for this control:**

Flows up to 70 l/min - 18.5 US gpm  
Pressure up to 240 bar - 3500 psi

**SL**

Electric push-pull control 3 positions  
12 Vdc

Without lever for electric control  
with override device

The stroke for this control is of 5 mm,  
for this reason the spools are different of standard.  
**The available spools are from 01 to 06.**

**E2**

Electric push-pull control 3 positions  
24 Vdc

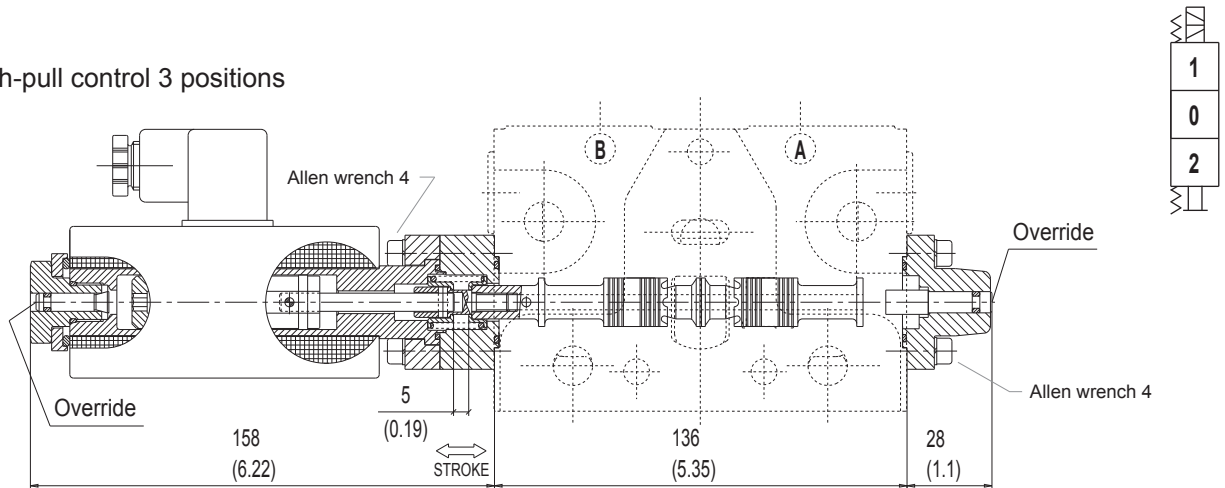

**ELECTRICAL DATA**

**PUSH - PULL SOLENOID**

- VOLTAGE: 12Vdc OR 24Vdc
- COIL POWER: 60 Watt at 20°C
- PROTECTION INDEX WITH CONNECTOR: IP 65
- HEAVY DUTY 70%

**ES**

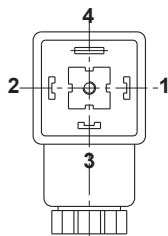

**CONNECTOR  
DIN 43650 - A/ISO 4400**

**ELECTRIC CONNECTIONS SCHEME**

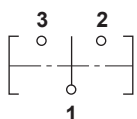

- 1) NEGATIVE POLE
- 2) SPOOL IN
- 3) SPOOL OUT
- 4) GROUND WIRE

To avoid an excessive wearing of the contacts, depending on the sparking of these parts, we suggest a suitable protection( for example diodes)

**Emergency lever for electric push-pull control**

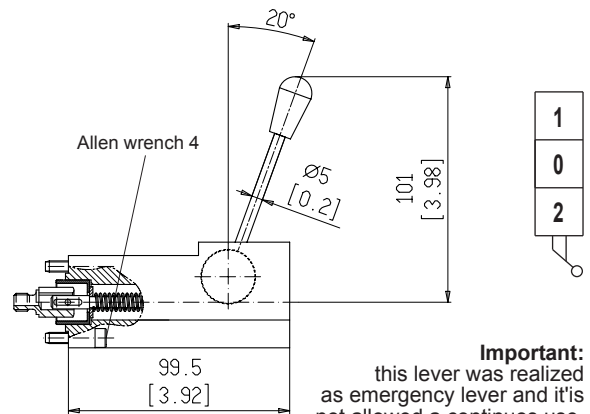

**Important:**  
this lever was realized as emergency lever and it's not allowed a continuous use.

**IP**

**Important:**  
when you order please specify top or side ports

Hydraulic proportional control

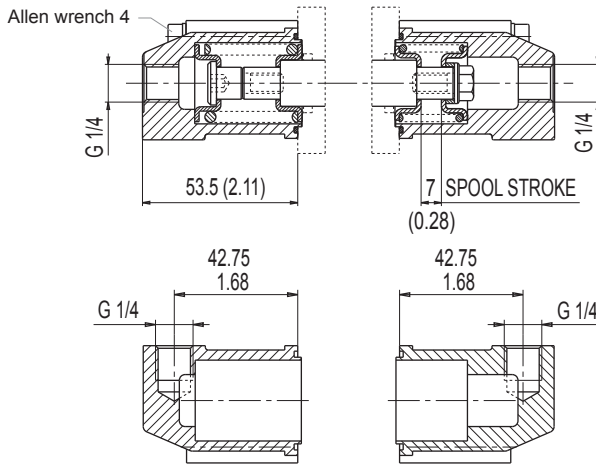

**Salami hydraulic  
2 axis joystick**

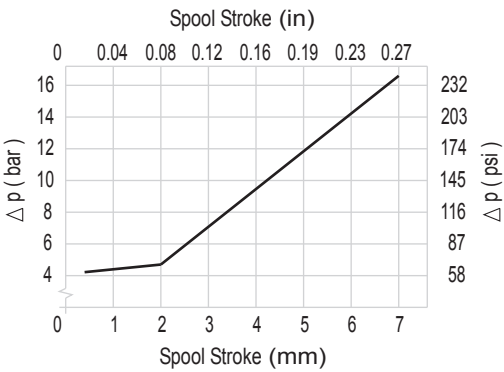
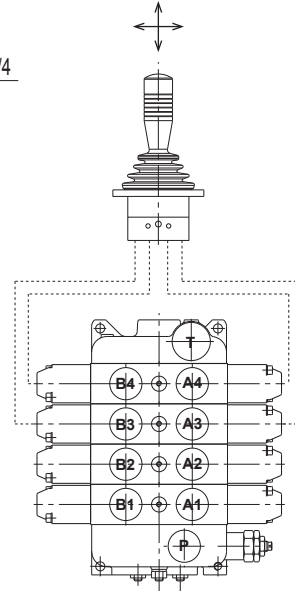

For more information please consult our catalogue  
SHRC hydraulic remote controls.

**IF**

Hydraulic proportional control  
with third float position (spool in)



**XA, XB, XF PORTS : G 1/4**

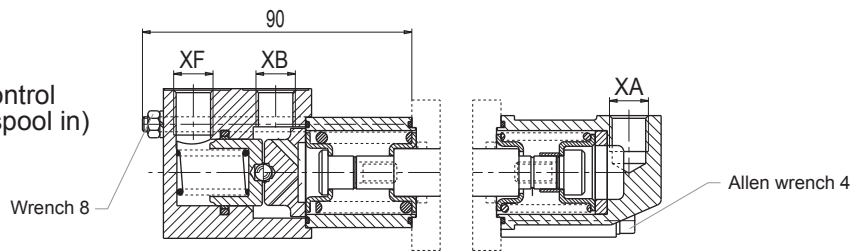

**OPERATING SCHEME**

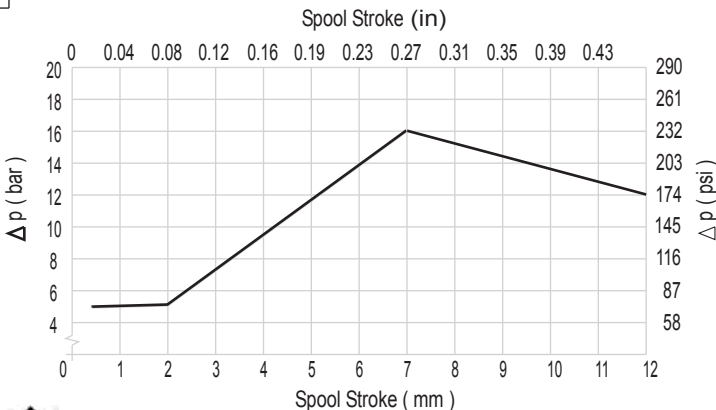
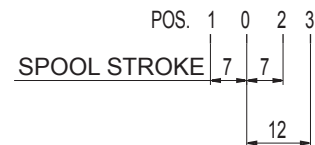
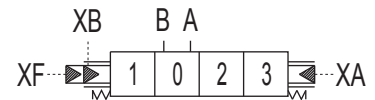

- XA, XB, XF → T ⇨ POS. 0
- Pressure → XB ⇨ POS. 1
- Pressure → XA, XF ⇨ POS. 2
- Pressure → XA ⇨ POS. 3

# DIRECTIONAL CONTROL VALVE SECTIONAL TYPE

# VD8A

Thought for all truck hydraulic applications

## PP/PO

Pneumatic proportional/on-off control

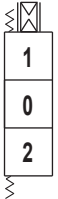
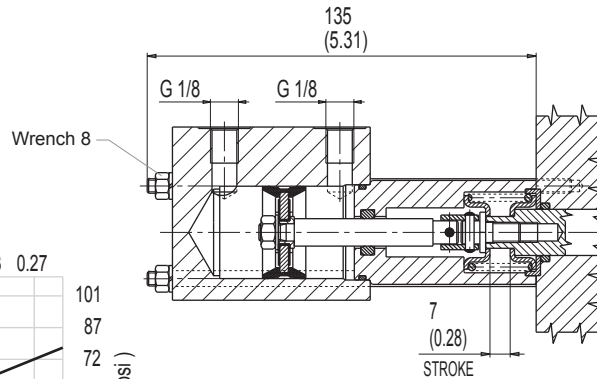
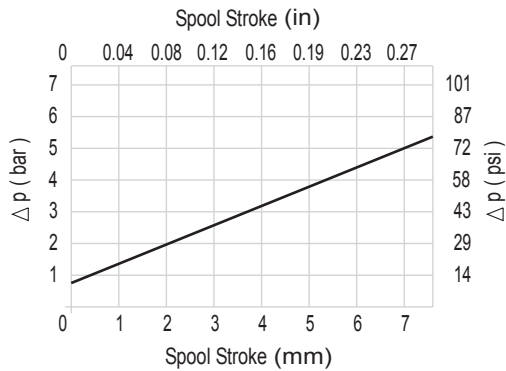

Pneumatic proportional/on-off control  
This control is at the same time proportional and on-off type, it depends if you use a pneumatic remote control proportional type (with the characteristic curve of diagram), or on-off type.



### ELECTRICAL DATA

- VOLTAGE: 12Vdc OR 24Vdc
- COIL POWER: 6 Watt at 20°C
- PROTECTION INDEX WITH CONNECTOR: IP 65

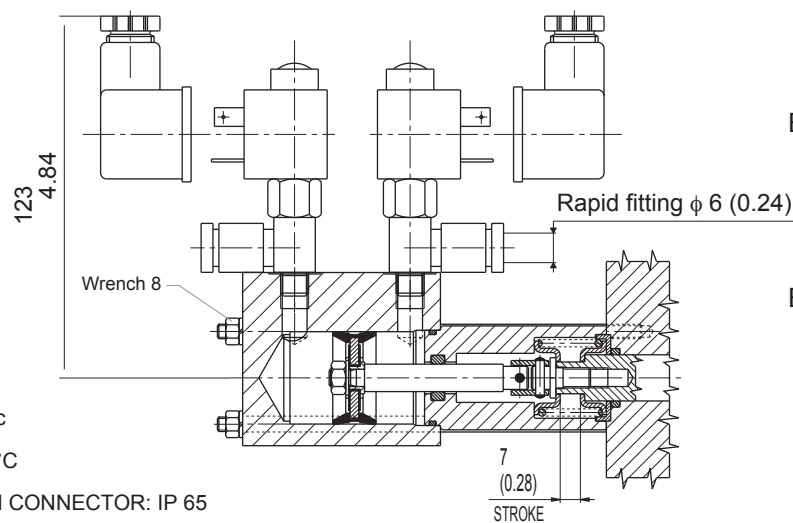

## P1

Electro-pneumatic on-off control - 12 Vdc

## P2

Electro-pneumatic on-off control - 24 Vdc

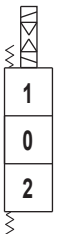

Starting from PP/PO adding the electro-valves you get P1 or P2

### OPERATING SCHEME

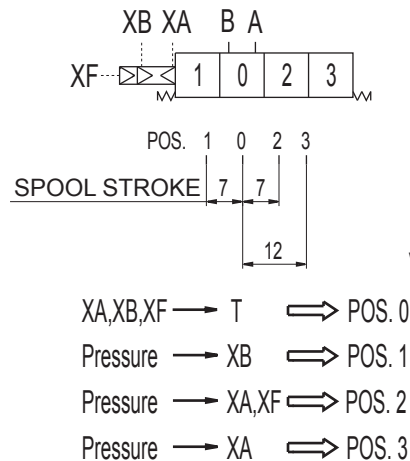

XA, XB, XF PORTS : G 1/4

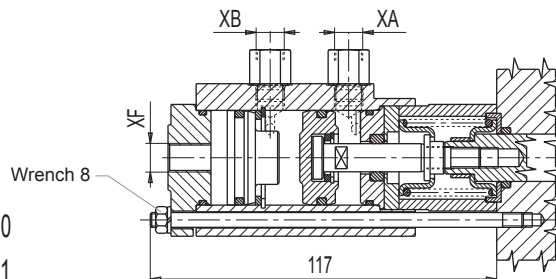

Pneumatic on-off control with third float position (spool in)



For electro-pneumatic control with third float position, please get in touch with our sales dept.



### Preliminary specifications about electro-hydraulic controls

Before to introduce electro-hydraulic single modules it is necessary to specify the adding hydraulic components necessary for the right functioning of it. As you can see in the drawing and hydraulic scheme it needs a pressure reducing valve "PRV" at the inlet of piloting circuit that reduce the pressure of "P" line at the max value of 25 bar (363 psi), a back pressure "CPV" on neutral line that assure a min. pressure of 8 bar (116 psi) and some accessories as fittings, pipe and filter. The pressure reduction at the piloting circuit inlet and the minimum value of neutral line can be obtained also

with external standard valves made by valve manufacturers, for this reason Salami electro-hydraulic controls can be supplied without "PRV" and "CPV".

In this case is necessary to specify it in phase of order.

Our standard supply has the "Tp" port opened, we recommend to connect it directly to tank because a counter-pressure could be cause of malfunction.

With reference to page 20, "OUTLET MODULES", the outlet U8 is shown in the hydraulic scheme here below, remember that with a special sleeve instead of "CPV" valve you can change U8 in a power beyond outlet type "U5".

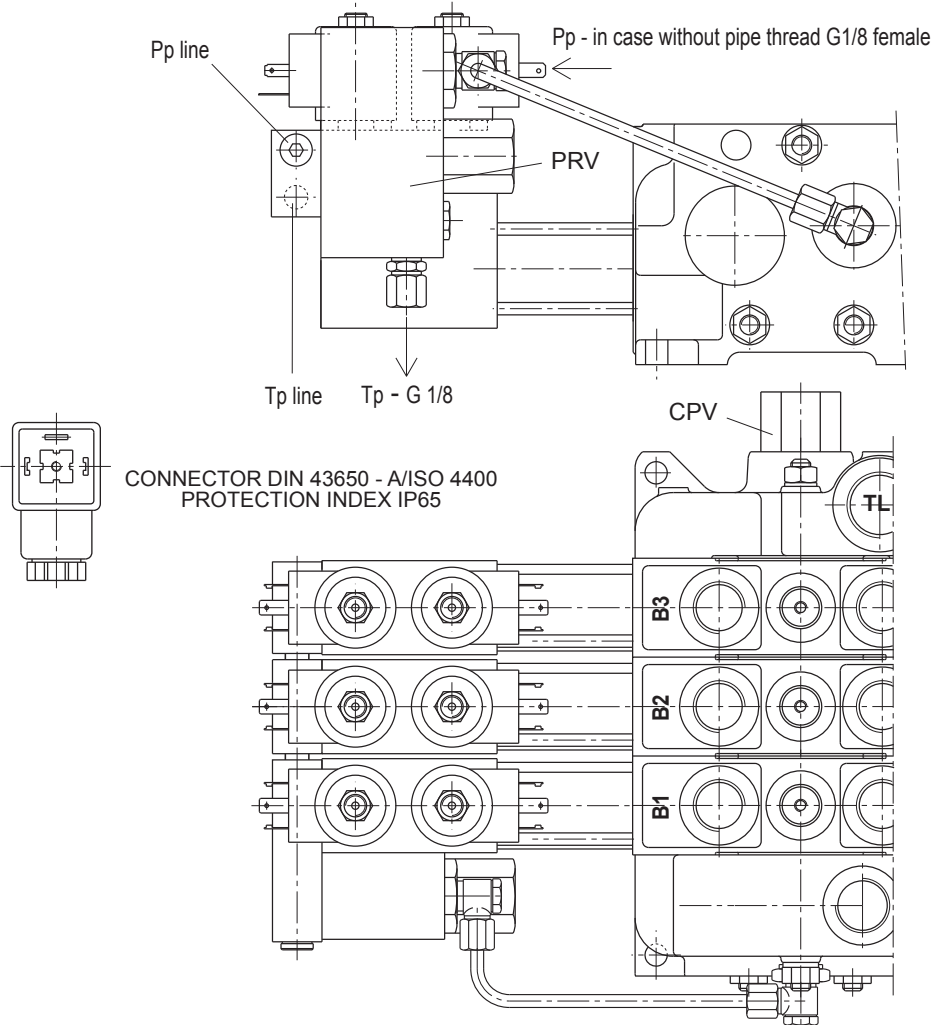

### INDEX

- PRV - pressure reducing valve
- CPV - counter pressure valve
- Pp - pressure piloting line
- Tp - tank piloting line
- PL - P port
- TL - T port

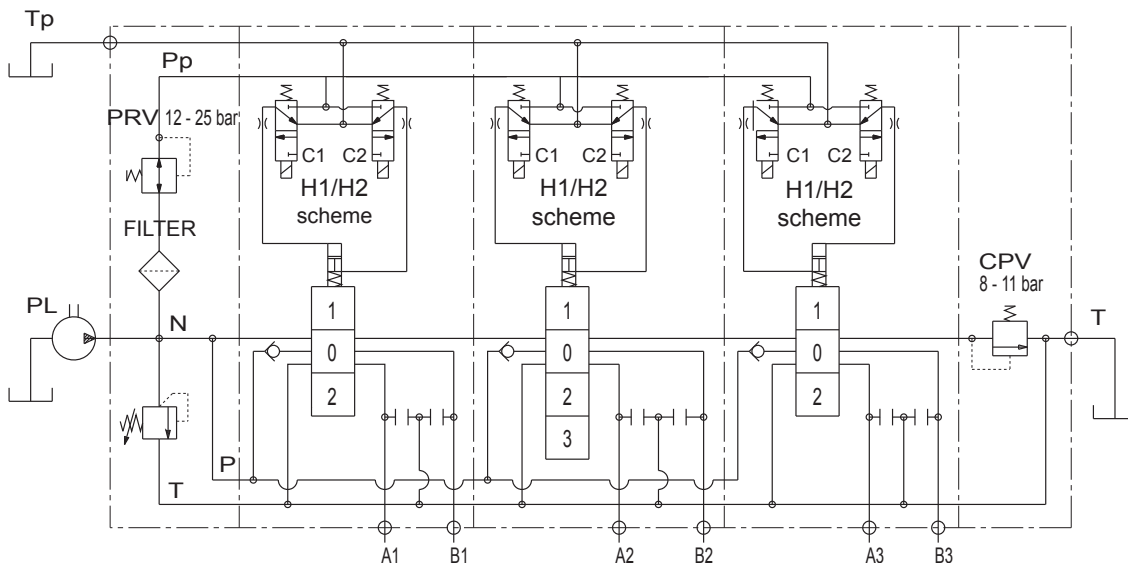

# DIRECTIONAL CONTROL VALVE SECTIONAL TYPE

# VD8A

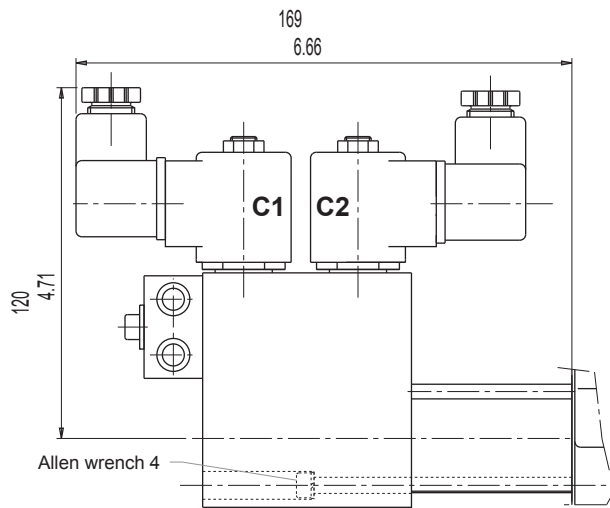

**OPERATING INSTRUCTIONS**  
please see the hydraulic circuit  
of page before

- C1 - C2** coils de-energized  $\Rightarrow$  POS. 0
- C1** coil energized  $\Rightarrow$  POS. 1
- C2** coil energized  $\Rightarrow$  POS. 2

**TECHNICAL DATA**

- MAX PRESSURE IN "P" 30 bar
- MAX FLOW 2 l/min
- AVAILABLE VOLTAGE 12 - 24 Vcc
- COIL RESISTANCE 12Vdc:7.2 $\Omega$  - 24Vdc:41.5 $\Omega$
- POWER 14 W (20°C)

## H1

ON-OFF  
electro-hydraulic control  
12 Vdc

## H2

ON-OFF  
electro-hydraulic control  
24 Vdc

## SPOOL POSITIONINGS

### C2

Spring centered to neutral position

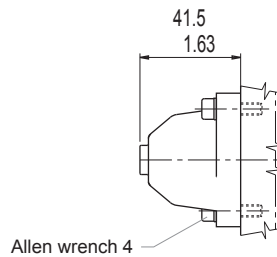
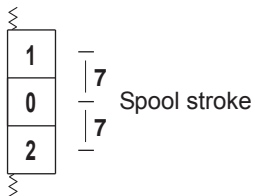

### C5

Two positions (neutral/pos. 2)  
with spring return in neutral

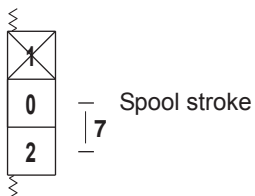

### C6

Two positions (neutral/pos. 1)  
with spring return in neutral

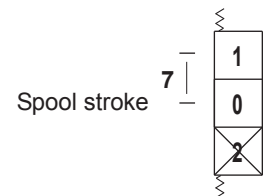

### C3

Spring centered to neutral  
(pivot threaded male  
for remote control)

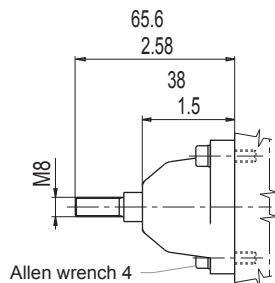
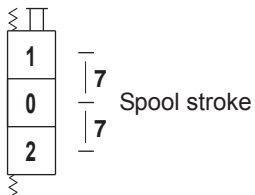

### C4

Spring centered to neutral  
(pivot threaded female  
for remote control)

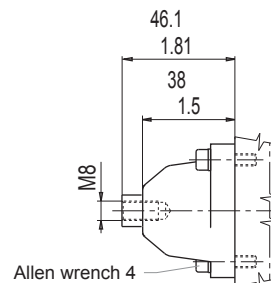
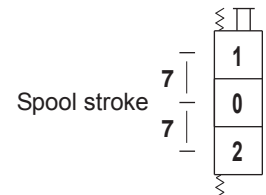

### C7

Two positions (pos. 1/pos. 2)  
with spring return in pos. 1

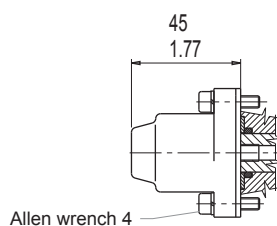
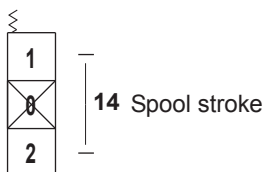

### C8

Two positions (pos1/pos. 2)  
with spring return in pos. 2

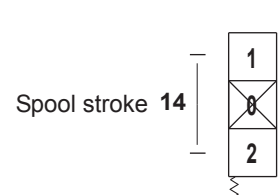



**R2**

Detent on pos. 1/pos. 2  
with spring return in neutral

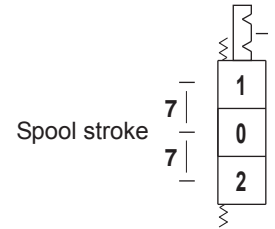

**R5**

Detent on pos. 2  
with spring return in neutral

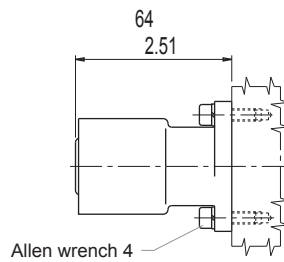
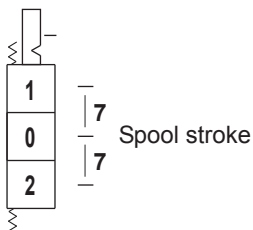

**R4**

Detent on pos. 1  
with spring return in neutral

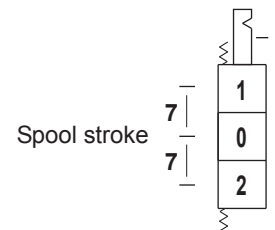

**R6**

Two positions with detent on pos. 2  
with spring return in neutral

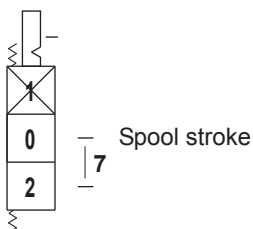

**R7**

Two positions with detent on pos. 1  
with spring return in neutral

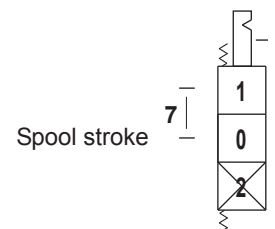

**CO**

Detent on each intermediate positions

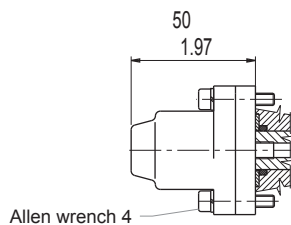
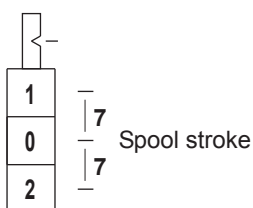

**R9**

Detent on pos. 1/pos. 2  
and neutral position

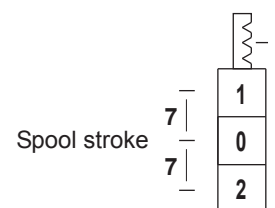

### F1

Detent on pos. 3  
with spring return in neutral

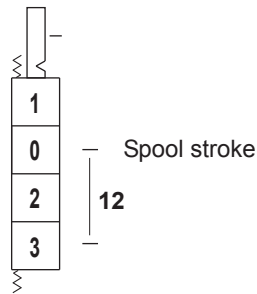

### F2

Detent on pos. 1/pos. 2/pos. 3  
with spring return in neutral

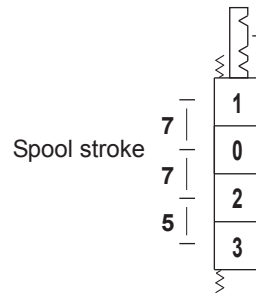

### F3

Detent on pos. 1/pos. 3  
with spring return in neutral

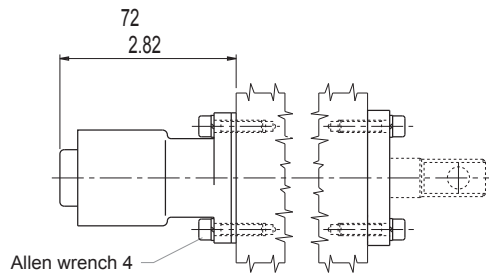
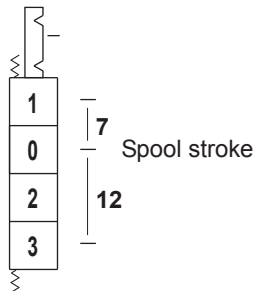

### F4

Detent on pos. 2/pos. 3  
with spring return in neutral

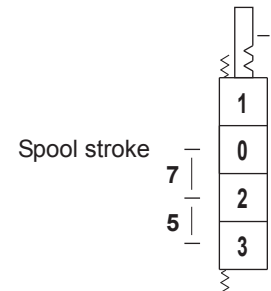

### F5

Detent on pos. 3  
with spring return in neutral

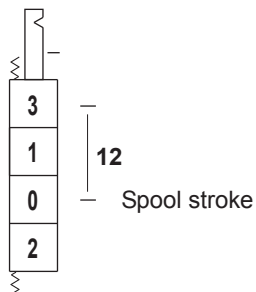

### F6

Detent on pos. 1/pos. 3  
with spring return in neutral

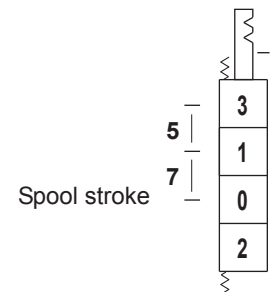

### F7

Detent on pos. 2/pos. 3  
with spring return in neutral

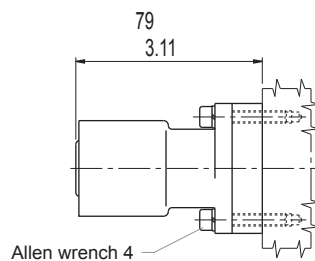
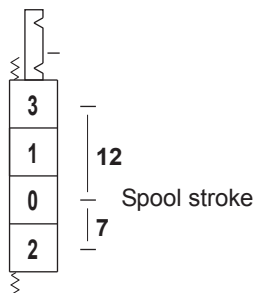

### F8

Detent on pos. 1/pos. 2/pos. 3  
with spring return in neutral

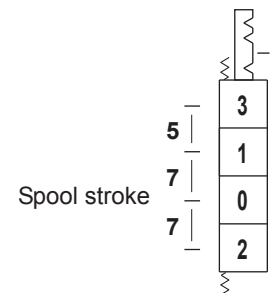

# DIRECTIONAL CONTROL VALVE SECTIONAL TYPE

# VD8A

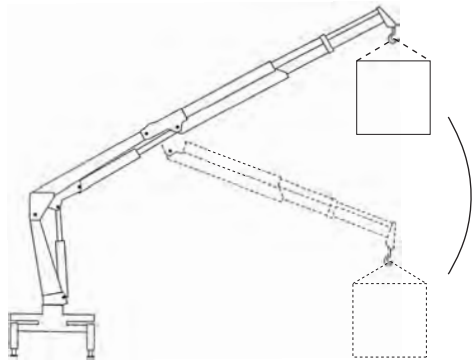

For manufacturers using load and overturning torque limiting device for hydraulically operated cranes, Salami VDM8 valve is available with some devices that allow the manufacturer to supply a pressure signal inside itself. This pressure signal, acting on the area of a piston of 18 mm (0.71 inc.) diameter, reacts to the force of the manual control bringing back the spool at the position 0.

These devices are only available in combination with manual control.

**D9**

Device for spool positioning in 0 from the positions 1 and 2 by an external pressure signal. For tie-rod connection.

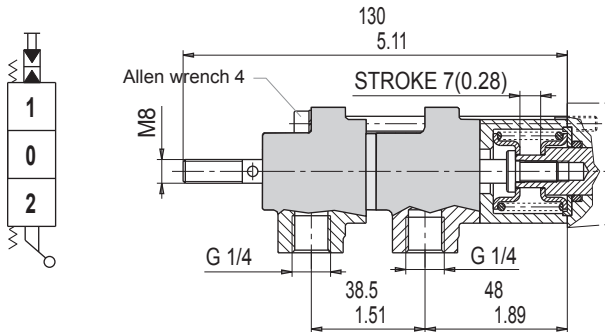

Device for spool positioning in 0 from the positions 1 and 2 by an external pressure signal.

**M3**

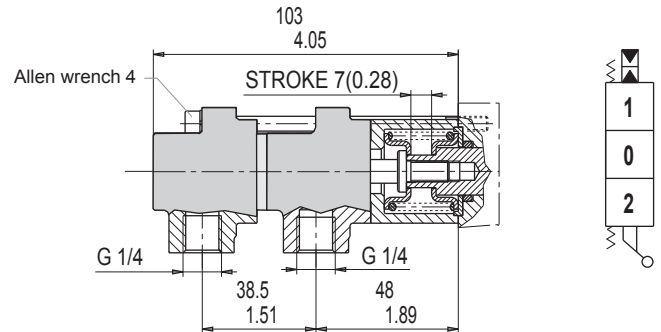

**D8**

Device for spool positioning in 0 from the position 1 by an external pressure signal. For tie-rod connection.

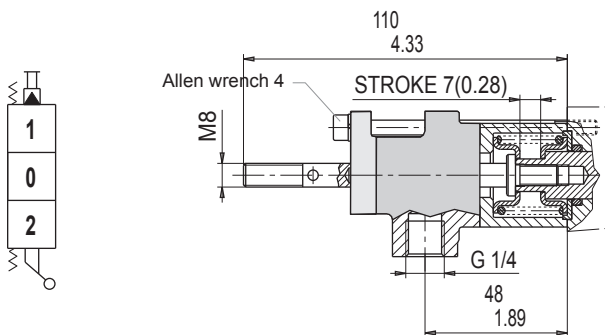

Device for spool positioning in 0 from the position 1 by an external pressure signal.

**M1**

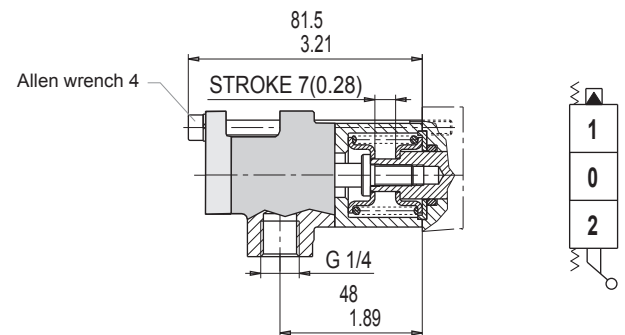

**D7**

Device for spool positioning in 0 from the position 2 by an external pressure signal. For tie-rod connection.

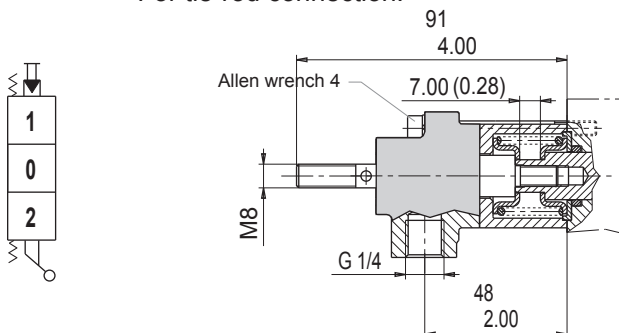

Device for spool positioning in 0 from the position 2 by an external pressure signal.

**M2**

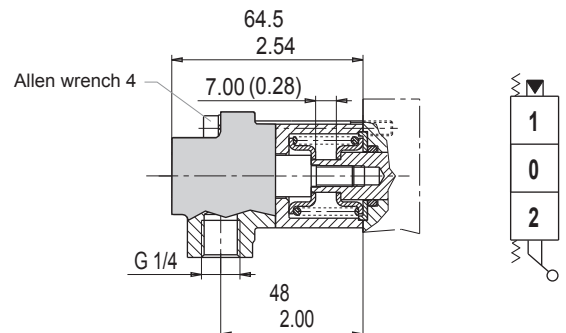

### CE

Pre-arrangement for electrical device

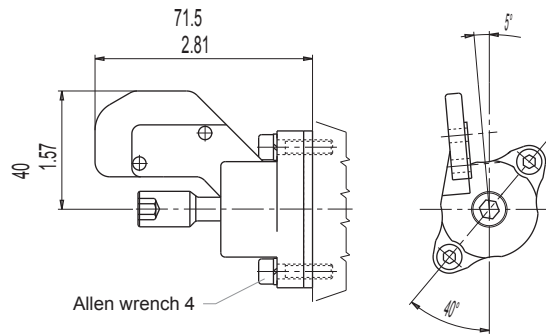
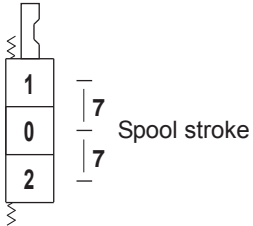

### CM

**MICROSWITCH TYPE: SAIA - BURGESS XGK - 88**  
For more information please get in touch with our sales dept.

Spool positioning with microswitch to start an electric motor (available also for single acting spools)

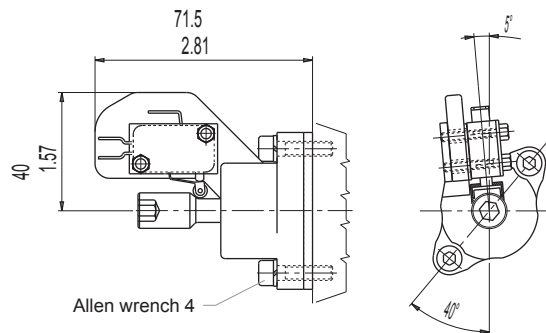
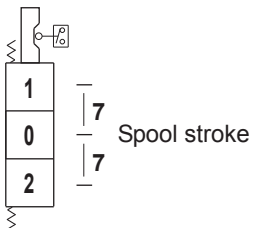

PROTECTION INDEX  
IP65

### CW

Spool positioning with waterproof microswitch to start an electric motor (available also for single acting spools)

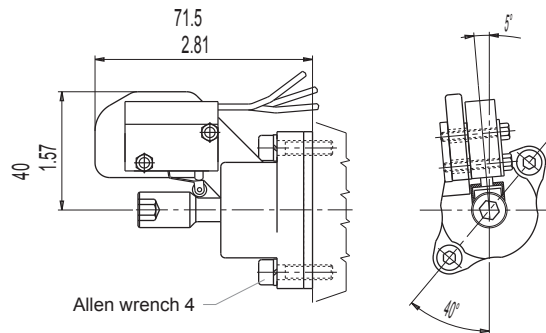
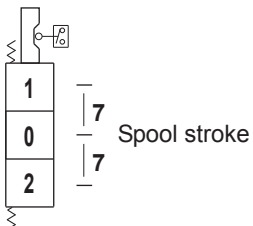

PROTECTION INDEX  
IP67

### CD

Spool positioning with double microswitch (available also for single acting spools)

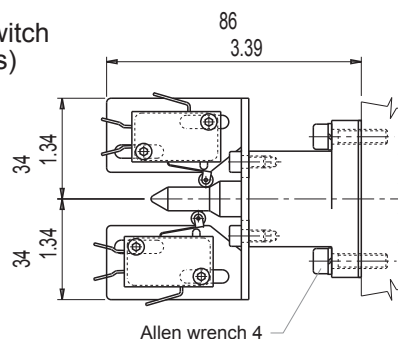
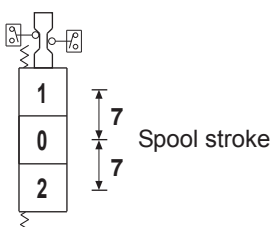

PROTECTION INDEX  
IP65

# DIRECTIONAL CONTROL VALVE SECTIONAL TYPE

# VD8A

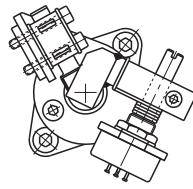
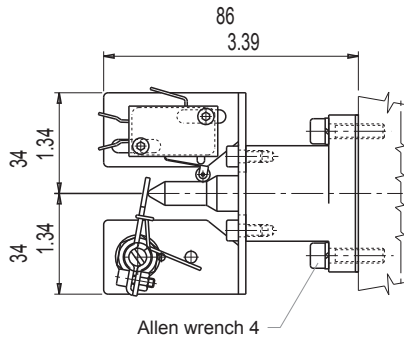

Spool positioning with microswitch to start an electric motor and potentiometer to run up speed motor (available also for single acting spools)

**PM**

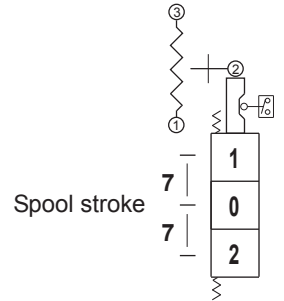
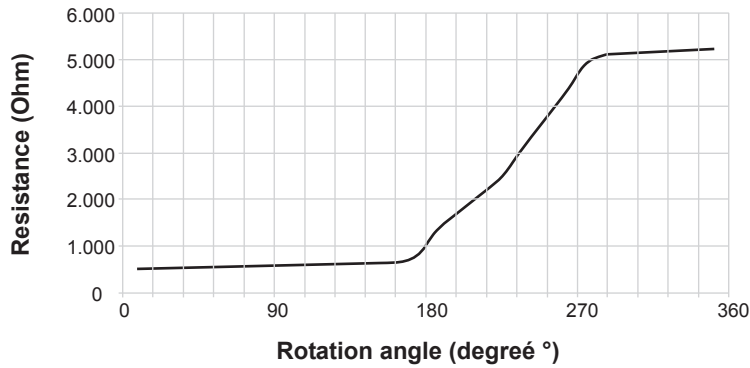

**IMPORTANT:**

When you order, please specify the setting pressure of the device.  
With this type of spool positioning a special machining of the body is required.

**G2**

Detent on pos. 1/pos. 2 with hydraulic kick-out

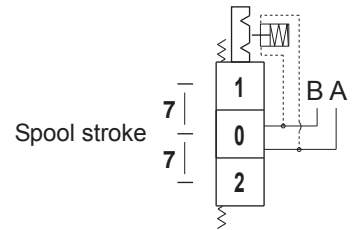

**G5**

Detent on pos. 2 with hydraulic kick-out

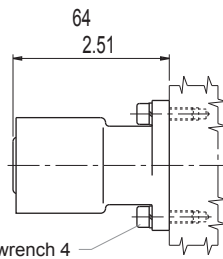
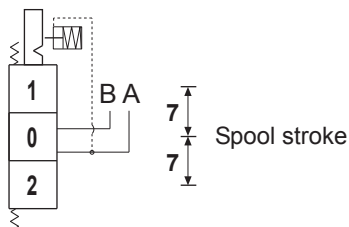

**G4**

Detent on pos. 1 with hydraulic kick-out

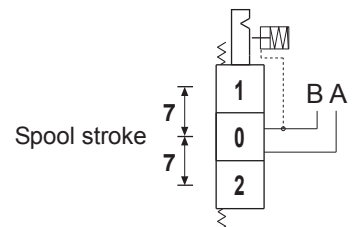

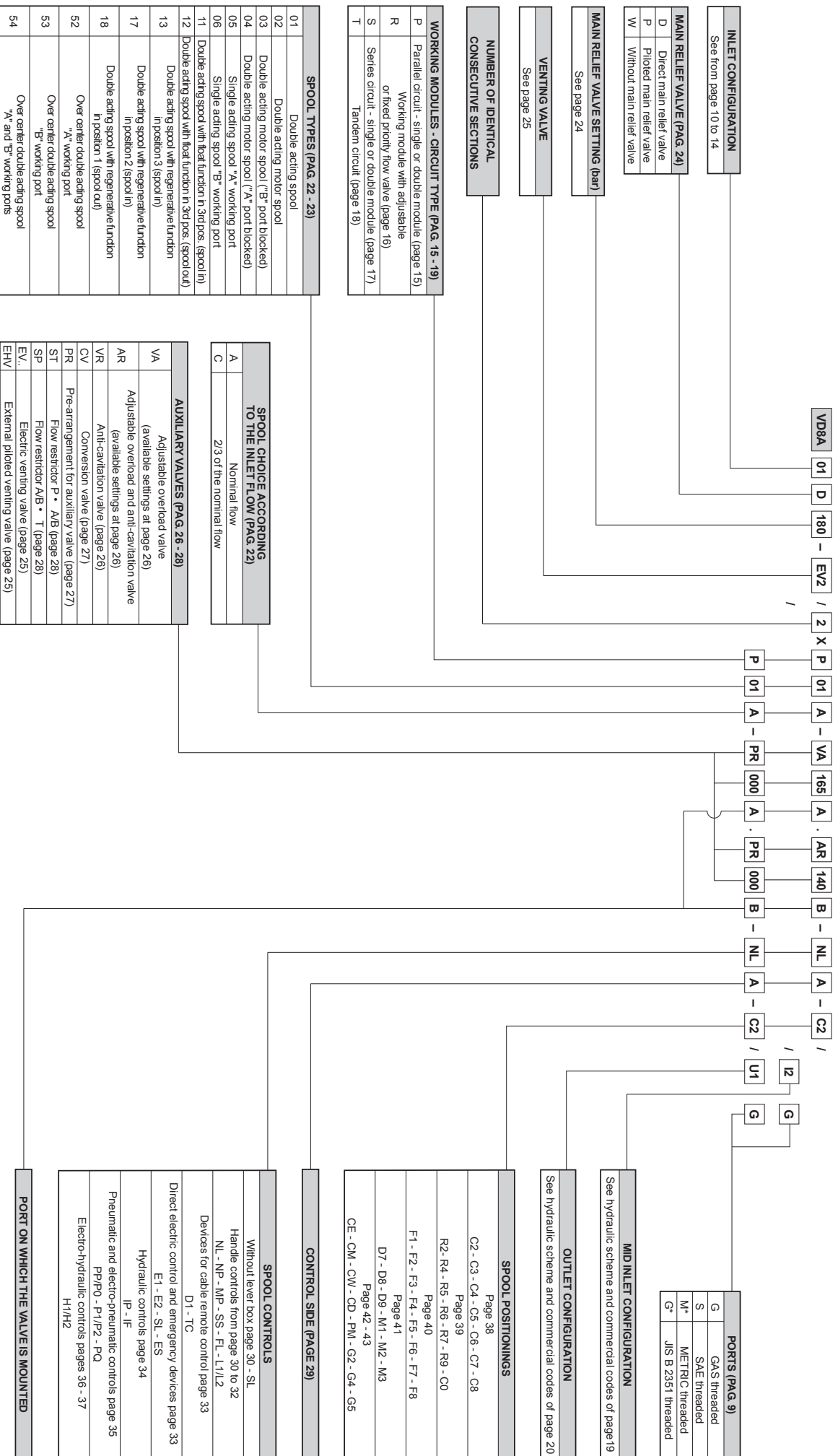

## DESCRIPTION OF THE NEW PRODUCT IDENTIFICATION LABEL

Based on the firm certification ISO 9001 - UNI EN 29001, section 4.8 (identification and traceability of the product), we have adopted a new identification label starting from the 1<sup>st</sup> march 1995. Pls, see following example:

A			
B			
C		D	
E	salami	F	G

- A = Product short description (eg. VD8A/FDD/U4G).**
- B = Customer part number.**
- C = Salami part number (eg. 6235 0025 0).**
- D = Production code (for Salami management)**
- E = Rotation sense (only for pumps).**
- F = Production date (see data sheet here below)**
- G = Progressive number of assembling.**

Only for pumps 2PB and 2PZ (except triple 2PB) the identification product is marked on the top of the pump body as shown here below:



**SALAMI 09/02**  
**MADE IN ITALY 4010998**  
**612271211 nr. 13**  
**2PB 19S B25 B5**

Product short description. \_\_\_\_\_  
 Salami part number and progressive number of assembling. \_\_\_\_\_  
 Production code (for Salami management). \_\_\_\_\_  
 Month and year of made: maybe in the future you can find this type of production date in the label beside too. \_\_\_\_\_  
 Rotation sense. \_\_\_\_\_

ASSEMBLED	1997	1998	1999	2000	2001	2002	2003	2004	2005	2006	2007	2008	2009	2010	2011	2012
JANUARY	7A	8M	9M	0M	1M	2M	3M	4M	5M	6M	7M	08M	09M	10M	11M	12M
FEBRUARY	7B	8N	9N	0N	1N	2N	3N	4N	5N	6N	7N	08N	09N	10N	11N	12N
MARCH	7C	8P	9P	0P	1P	2P	3P	4P	5P	6P	7P	08P	09P	10P	11P	12P
APRIL	7D	8Q	9Q	0Q	1Q	2Q	3Q	4Q	5Q	6Q	7Q	08Q	09Q	10Q	11Q	12Q
MAY	7E	8R	9R	0R	1R	2R	3R	4R	5R	6R	7R	08R	09R	10R	11R	12R
JUNE	7F	8S	9S	0S	1S	2S	3S	4S	5S	6S	7S	08S	09S	10S	11S	12S
JULY	7G	8T	9T	0T	1T	2T	3T	4T	5T	6T	7T	08T	09T	10T	11T	12T
AUGUST	7H	8U	9U	0U	1U	2U	3U	4U	5U	6U	7U	08U	09U	10U	11U	12U
SEPTEMBER	7I	8V	9V	0V	1V	2V	3V	4V	5V	6V	7V	08V	09V	10V	11V	12V
OCTOBER	7J	8Z	9Z	0Z	1Z	2Z	3Z	4Z	5Z	6Z	7Z	08Z	09Z	10Z	11Z	12Z
NOVEMBER	7K	8X	9X	0X	1X	2X	3X	4X	5X	6X	7X	08X	09X	10X	11X	12X
DECEMBER	7L	8Y	9Y	0Y	1Y	2Y	3Y	4Y	5Y	6Y	7Y	08Y	09Y	10Y	11Y	12Y



## **WARRANTY**

- We warrant products sold by us to be free from defects in material and workmanship.
- Our sole obligation to buyer under this warranty is the repair or replacement, at our option, of any products or parts thereof which, under normal use and proper maintenance, have proven defective in material or workmanship, this warranty does not cover ordinary wear and tear, abuse, misuse, averloading, alteration.
- No claims under this warranty will be valid unless buyer notifies SALAMI in writing within a reasonable time of the buyer's discovery of such defects, but in no event later than twelve (12) months from date of shipment to buyer.
- Our obligation under this warranty shall not include any transportation charges or cost of installation, replacement, field repair, or other charges related to returning products to us; or any liability for direct, indirect or consequential damage or delay. If requested by us, products or parts for which a warranty claim is made are to be returned transportation prepaid to our factory. The risk of loss of any products or parts thereof returned to SALAMI will be on buyer.
- No employee or representative is authorized to change any warranty in any way or grant any other warranty unless such change is made in writing and signed by an officer of SALAMI.





SALAMI spa  
via Emilia Ovest 1006  
41100 Modena Italy  
telefono +39-059-387411  
telefax +39-059-387500  
export@salami.it - www.salami.it



SALAMI ITALIA srl  
strada Pelosa 183  
S. Pietro in Trigogna VI Italy  
telefono +39-0444-240080  
telefax +39-0444-240204  
salami.italia@salami.it



SALAMI ESPAÑA  
Poligono Industrial Armenteres  
C/Primer de Maig, 18, Nave 4  
08980 San Feliu de Llobregat  
Barcelona  
telefono +34-93-6327288  
telefax +34-93-6667826  
info@salamispain.com



SALAMI FRANCE  
22, rue Louis Salliant  
69120 Vaulx en Velin  
Lyon  
telefono +33-04-78809941  
telefax +33-04-78803669  
e.pasian@wanadoo.fr



149 S0. Chenango St. Ext.,  
GREEN, NY 13778  
Tel.: +1-607-6565702  
Fax.: +1-607-6565704  
info@salamihydraulics.com