

DESCRIPTION

- AP-10 is a high pressure gear pump with cast iron end caps and an aluminum housing.
- Standard mounting flange is **SAE AA-2 bolt**.
- Standard ports are **SAE-8 inlet** and **SAE-6 outlet**.
- Standard drive shaft is **1/2" straight shaft with 1/8" key**.
- All aluminum construction is available.

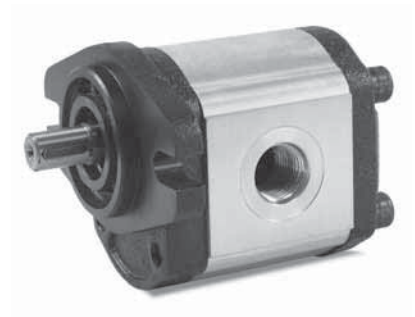

TECHNICAL DATA

- Filtration: 25 micron or better
- Oil Viscosity: 6 to 200 cSt
- Inlet Pressure: 12 to 32 psi absolute
- Temperature: Oil: -25°C to 80°C / -12°F to 175°F
Ambient: -22°C to 55°C / -8°F to 130°F
- Port Sizes: Inlet: SAE-8 (3/4"-16 UNF)
Outlet: SAE-6 (9/16"-18 UNF)

Model	GPM @ 1800 rpm	Displacement		Pressure		Speed RPM		Weight	
		cm3/rev	cu.in/rev	PSI	BAR	Min.	Max.	Lbs.	Kg
AP-10-1.3	0.55	1.3	0.07	3625	250	500	5000	4.0	1.81
AP-10-1.6	0.76	1.6	0.097	3625	250	500	5000	4.3	1.95
AP-10-2.0	0.94	2.0	0.12	3625	250	500	5000	4.2	1.90
AP-10-2.7	1.25	2.7	0.16	3625	250	500	5000	4.5	2.04
AP-10-3.4	1.56	3.4	0.20	3625	250	500	5000	4.5	2.04
AP-10-4.1	1.95	4.1	0.25	3625	250	500	4000	4.8	2.17
AP-10-5.1	2.73	5.1	0.31	3625	250	500	4000	5.0	2.27
AP-10-6.1	2.88	6.1	0.37	3625	250	500	4000	5.0	2.27
AP-10-8.0	3.82	8.0	0.49	3625	250	500	4000	5.2	2.36

- Flow rate in gpm - Displacement (cu.in/rev) X speed (rpm)/231
- Volumetric efficiency % >93

Hydraulic Gear Pump AP-10



INSTALLATION DATA

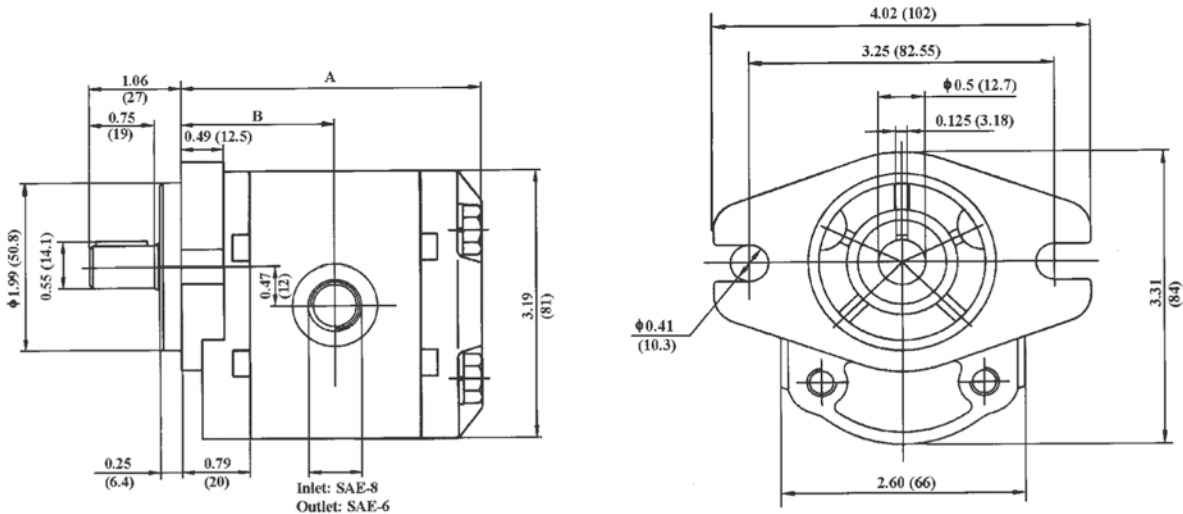

Model	A		B	
	mm	inch	mm	inch
AP-10-1.3	82	3.23	42	1.65
AP-10-1.6	83	3.27	43	1.69
AP-10-2.0	84	3.31	43	1.69
AP-10-2.7	86	3.39	44	1.73
AP-10-3.4	88	3.46	45	1.77

Model	A		B	
	mm	inch	mm	inch
AP-10-4.1	90	3.54	46	1.81
AP-10-5.1	93	3.66	47.5	1.87
AP-10-6.1	96	3.78	49	1.93
AP-10-8.0	107	4.28	58	2.29

ORDERING INFORMATION

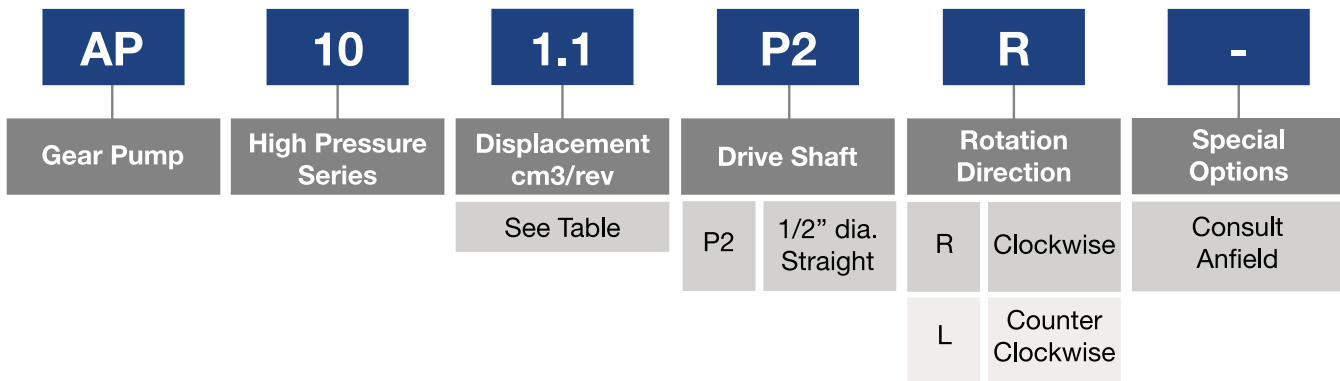

Viewed from drive shaft end